



Historic Bridge Adoption Information Packet

Limestone County

County Road (CR) 244

Tehuacana Creek

November 2024

Table of Contents

Announcement.....	3
Bridge Location	4
Bridge Information	4
Bridge Condition.....	4
Historic Significance of the Bridge.....	4
Condition Photos and Descriptions	Error! Bookmark not defined.
Bridge Photographs	11

Announcement

The Texas Department of Transportation (TxDOT) seeks adopters for the historic bridge detailed below for reuse according to federal transportation and historic preservation laws. The bridge is located in Limestone County, on County Road (CR) 244 crossing Tehuacana Creek.

Letters of interest and/or reuse proposals will be accepted until 5 p.m. on **February 5, 2025**. TxDOT is currently undergoing alternatives analysis for this project. The outcome of the analysis may impact the availability of this bridge. Priority for assistance will be given to public entities seeking to reuse the bridge in a public or publicly visible space. Bridges available through this program are not suitable for vehicular service. All rehabilitation work must conform to the Secretary of the Interior's *Standards for Rehabilitation* in consultation with the Texas Historical Commission (THC).

Interested parties may request additional information, indicate an interest, or submit a reuse proposal by contacting:

Darrell Dooley, Environmental Project Planner
TxDOT Waco District
100 South Loop Drive
Waco, TX 76704
Phone Number: (254) 867-2700
Email address: darrell.dooley@txdot.gov



Bridge Location

- **County:** Limestone
- **Highway or Facility:** County Road (CR) 244
- **Feature Crossed:** Tehuacana Creek
- **GIS Locational Information** <https://arcg.is/OjLv04>

Bridge Information

- **Bridge Owner** Limestone County
- **Main-span Type:** Warren pony truss
- **Main-span Length** 70 feet
- **Roadway Width** 15 feet
- **Year Built** 1920
- **Builder** McCall-Moore Engineering Company

Bridge Condition

The CR 244 at Tehuacana Creek bridge is in poor condition. Corrosion and section loss in the fracture critical truss members have reduced the bridge's load carrying capacity, and if left untreated, could lead to collapse. The bridge cannot safely carry emergency vehicles due to its reduced load-carrying capacity. Additionally, at 15-feet-wide, the bridge effectively serves as a one-lane crossing due to its narrow width.

Historic Significance of the Bridge

In 2014, the Texas State Historic Preservation Office (SHPO) determined that all extant metal truss bridges in Texas are historically significant at the local level as rare surviving examples of their type. This 1920 Warren pony truss retains the essential physical features that enable it to convey the historic character of metal truss bridges from the early-to-mid-20th century. The CR 244 bridge was moved to its current location in 1928 from the former crossing of State Highway 14 over Tehuacana Creek, but the move does not impact its integrity.

Condition Photos and Descriptions

The following photos show areas of the truss needing repair. Some repairs will be required prior to converting the bridge to pedestrian use, while others can be deferred to a later date. Each photo is accompanied by a description of the repair and recommendations for timing of the repair. Please note that additional repairs may be uncovered while moving the truss, or while completing rehabilitation activities. Other costs required for converting the bridge to pedestrian use include foundations at the new location, a pedestrian rail, and a pedestrian walkway of a width to be determined by engineering analysis. Finally, the truss will need to be moved from the current site to the new location. Costs to the recipient will be dependent on distance to be moved and may be partially or fully covered the State. The new owner is responsible for conducting a site assessment to determine the full scope of needed repair.

Photo 1: Truss End Post



The end posts have severe section loss to the inboard webs/flanges and a few locations with severe corrosion resulting in holes. The damage must be cleaned and painted, and the section restored. These repairs can be completed after moving the truss but must be completed prior to converting the truss to pedestrian use.

Photo 2: Truss Connections



Pack rust between lower chord gusset plates and truss members is typically 1/2" thick, with isolated locations up to 1", resulting in bowing of the gusset plates. Upper chord gusset plates also exhibit similar pack rust. These repairs can be completed after moving the truss and can be deferred further if needed. However, corrosion will continue until addressed by cleaning, painting, and sealing areas of deformation where water will collect. TxDOT highly recommends cleaning and painting the entire structure.

Photo 3: Corrosion at bottom chord with section loss



Lower chord members, horizontal angle legs; locations of 100% section loss, and pitting up to 5/16" deep in isolated locations. Pitting is also typical within the panel points. The damage must be cleaned and painted, and the section restored. These repairs can be completed after moving the truss but must be completed prior to converting the truss to pedestrian use.

Photo 4: Pack rust on vertical members



The vertical members have pack rust up to 1-5/8" thick for a 19" length above the floorbeam connections. These repairs can be completed after moving the truss and can be deferred further if needed. However, corrosion will continue until addressed by cleaning, painting, and sealing areas of deformation where water will collect.

Photo 5: Section loss on vertical members



Vertical members exhibit up to 100% section loss in isolated areas throughout the structure. The damage must be cleaned and painted, and the section restored. These repairs can be completed after moving the truss but must be completed prior to converting the truss to pedestrian use.

Photo 6 and 7: Truss Dimensions in Elevation and Cross Section

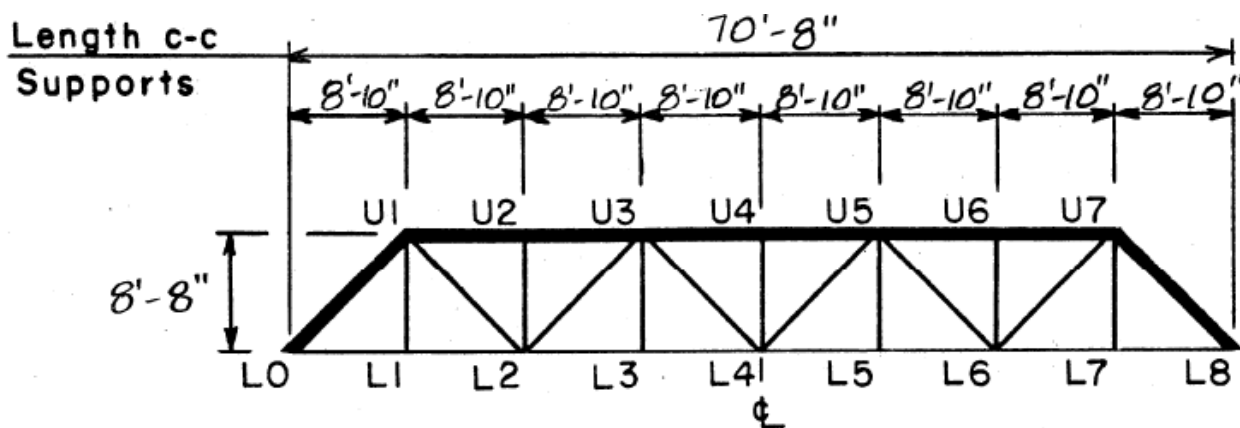

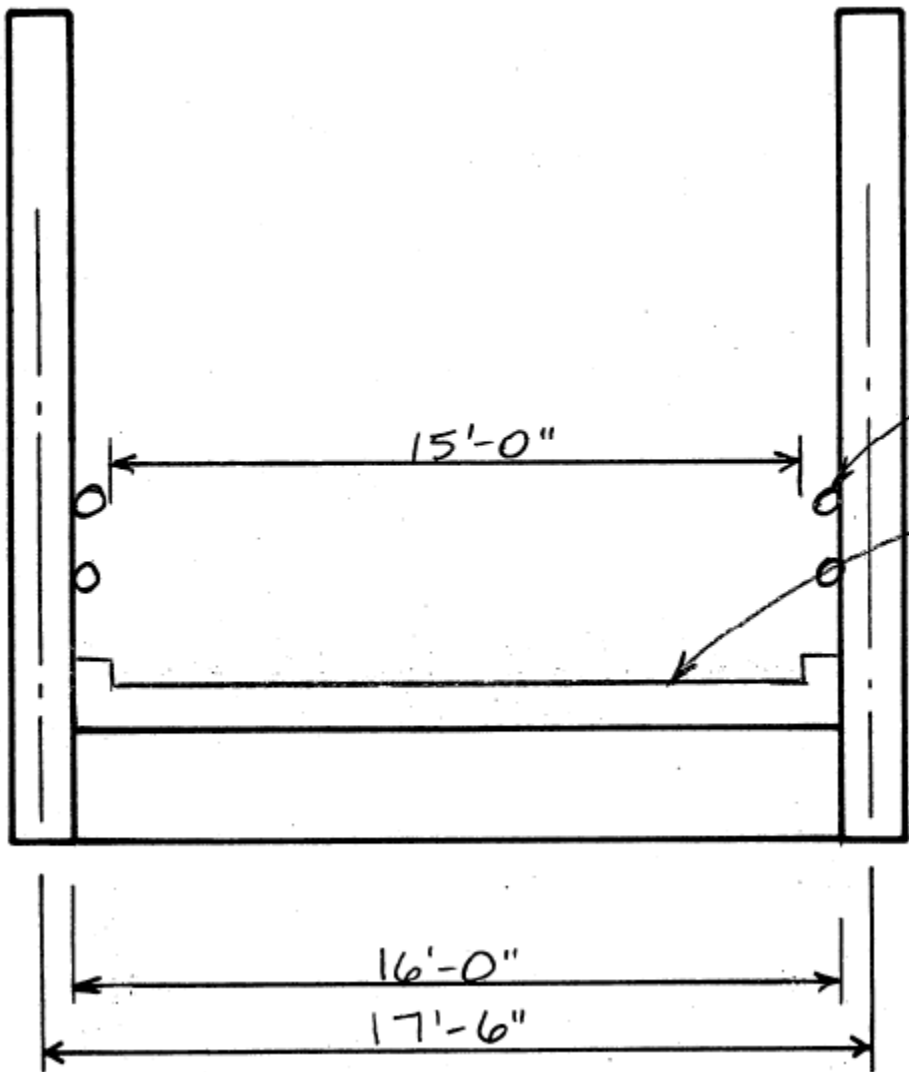

The configuration and dimensions of the structure are shown to assist in estimating costs associated with moving the truss, and for purchasing and installing the pedestrian walkway and railing. The 8-inch concrete deck will need to be removed prior to moving the truss. The width of the walkway will need to be determined from pedestrian load rating calculations provided by a professional engineer.

Bridge Photographs



