



# Monument Specifications

## Surveying Section, Right of Way Division

Revised: 4/14/2026

# Contents

- INTRODUCTION..... 3**
- SECTION I: MARKER DISKS AND CAPS ..... 3**
- ROW MARKER .....3
- SURVEY CONTROL POINT MARKER.....4
- BENCHMARK .....5
- PROPERTY CORNER MARKER.....6
- DENIAL OF ACCESS MARKER.....6
- INTERIM RIGHT-OF-WAY MARKER .....7
- TXDOT EASEMENT .....9
- TXDOT REFERENCE MARKER .....9
- SECTION II: METHODS FOR SETTING MONUMENTS..... 10**
- ROCK SETTING ..... 10
- POURED CONCRETE SETTING ..... 11
- DATUM POINT ROD ..... 13
- LIGHT/INTERIM DUTY SETTING ..... 15
- SECTION III: MONUMENT DETAIL SPECIFICATION SHEETS ..... 17**

## Introduction

These specifications provide the TxDOT approved methods of setting monuments in various soil conditions. Each disk has an assigned National Institute of Government Purchasing (NIGP) Commodity Code, and TxDOT District Survey Coordinators can order from TxDOT warehouses. The use of various setting methods is determined by the District Survey Coordinator. NIGP codes for statewide distribution of disks will be given only to the standard disks listed here or new configurations approved by the TxDOT Committee on Geomatics and Surveying (COGS).

## Section I: Marker Disks and Caps

### ROW Marker

This bronze Right-of-Way marker (see Figure 1) has remained unchanged for many years. Only slight changes to the embossed face of this disk will be noticed. The marker is a 4-inch domed-top disk with an open area for a punch mark. Set in a poured concrete post or drilled in rock or concrete with epoxy adhesive and referred to as a Type II monument. Consult with the District Survey Coordinator and the Survey Manual for specifics on placement.



*Figure 1 Example Bronze ROW Marker; NIGP 30578533009; Marker, Survey, Bronze 4-inch, ROW.*

This aluminum dome-top disk (see Figure 2) shall be stamped "TEXAS DEPT OF TRANSPORTATION R.O.W. MONUMENT". The face of the disk shall be smooth for stenciling of required survey data. With a chisel or center punch, mark the exact location of the Right-of-Way line on the aluminum disk.



*Figure 2 Example Aluminum ROW Marker.*

## **Survey Control Point Marker**

This aluminum dome-top disk (see Figure 3) is pre-punched for setting as project control points. The triangle symbol is used to denote horizontal control. This type of monument may also have an elevation value. There is a configuration for setting in rock/concrete and a configuration for use as a rebar cap. Both configurations come with an imbedded magnet for aid in location with a magnetic detector. With the plastic spacer removed, the cap can be driven onto a  $\frac{3}{4}$  inch rebar. If set with rebar in soil, the TxDOT District Registered Professional Land Surveyor (RPLS) pre-approval is required to appropriately determine width and length of rebar (iron rod). If the TxDOT District does not staff an RPLS, preapproval must be obtained by the ROW Division Survey Section.



*Figure 3 Example Control Point Marker. Profile view to set in concrete and set with 5/8-inch rebar. Configuration A: NIGP 30578532464. Marker, Survey, Control point, 3 ½-inch alum for rock and concrete. Configuration B: NIGP 30578532514. Marker, Survey, Control point, 3 ¼-inch alum rebar cap.*

## **Benchmark**

This aluminum dome-top disk (see Figure 4) is intended for permanent elevation stations. The engraved mark is a standard notation for benchmarks. The rock and concrete configuration can be mounted on a vertical surface if necessary. Not to be set in soil.



*Figure 4 Example Benchmark Marker. Profile view to set in concrete and set with 5/8-inch rebar. Configuration A: NIGP 30578532472. Marker, Survey, Benchmark, 3 ½-inch alum for rock or concrete. Configuration B: NIGP 30578532506. Marker, Survey, Benchmark, 3 ¼-inch alum cap for 5/8-inch rebar.*

## Property Corner Marker

This smaller 2-inch diameter disk (see Figure 5) is used to mark the intersection of existing property lines with new Right-of-Way. There is a configuration for setting in rock/concrete and a configuration for use as a rebar cap. If set with rebar in soil, a sufficient rod length is to be used to minimize movement. Rod length shall be approved by the District Survey Coordinator. Both configurations come with an imbedded magnet for aid in location with a magnetic detector.



*Figure 5 Example Property Corner Marker. NIGP 30578532209. Marker, survey, property corner, 2-inch alum cap for 5/8-inch rebar.*

## Denial of Access Marker

This 2-inch diameter disk (see Figure 6) is used to mark points on the Right-of-Way line indicating control of access. The face is flat and open for stamping pertinent information such as “beginning,” “ending” or an arrow indicating direction of denied access. There is a configuration for setting in rock/concrete and a configuration for use as a rebar cap. If set with rebar in soil, a sufficient rod length is to be used to minimize movement. Rod length shall be approved by the District Survey Coordinator. Both configurations come with an imbedded magnet for aid in location with a magnetic detector.



*Figure 6 Example Denial of Access Marker. NIGP 30578532100. Marker, survey, denial of access, 2-inch alum for 5/8-inch rebar.*

## **Interim Right-of-Way Marker**

The pink plastic 1 ¾-inch cap stamped "TXDOT SURVEY MARKER RIGHT OF WAY" for a 5/8-inch rebar is an interim/temporary ROW marker used during construction (see Figure 7). The pink plastic 1 ¾-inch cap stamped "TXDOT SURVEY MARKER RIGHT OF WAY" may be substituted for a different style of cap or size of rebar; the cap and rebar shall be described for its material, dimensions, and stamp (need District Survey Coordinator pre-approval). The monument may be referred to as a "Type III Monument".

This monument requires the TxDOT District Registered Professional Land Surveyor (RPLS) or District Survey Coordinator pre- approval before use. If the TxDOT District does not staff an RPLS preapproval may be obtained by the ROW Division Survey Section.

The District Survey Coordinator or TxDOT Staff assigned by the Transportation Planning and Development Director may keep track of the project's progress and replace the Interim ROW Marker with the Bronze 4" ROW Marker during or after project construction.

When should this monument be considered for use?

- The district has deliberately chosen to set Type II ROW Markers after completion of the project.
- A Type II ROW Marker cannot be set at a PC, PT, or PI, etc., due to interference or obstruction.
- Lack of permission to set a Type II.

The following statement may be incorporated when setting an Interim ROW monument as the original monument instead of the preferred standard Type II monument.

“\*\*The monument described and set in this call may be replaced with a TxDOT Type II ROW Marker upon the completion of the highway construction project under the supervision of a Registered Professional Land Surveyor either employed by or retained by TxDOT.”

For Board’s approval, see the Texas Board of Professional Land Surveying meeting minutes from February 11th, 2002.

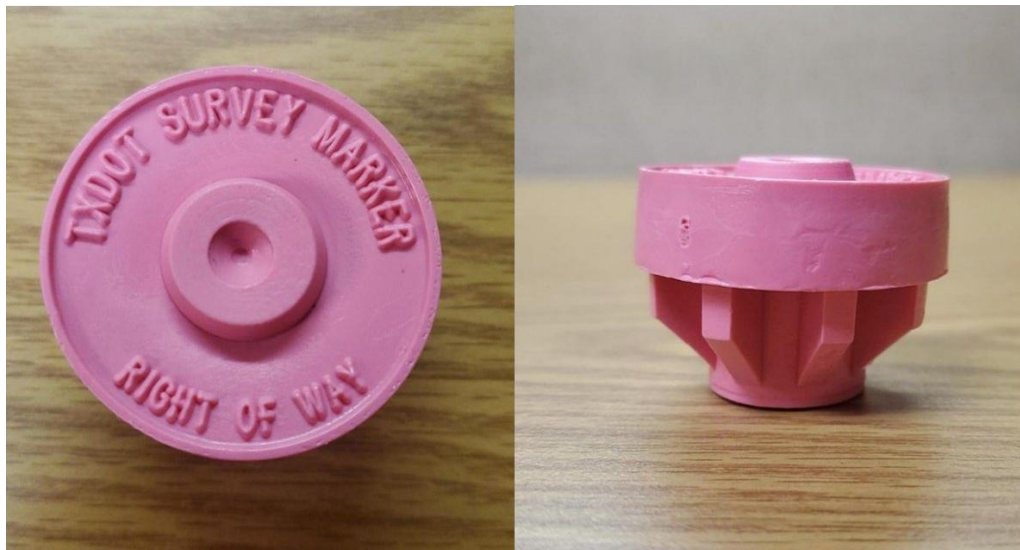

*Figure 7 Example Interim ROW Marker for 5/8-inch rebar. The style of cap or size of rebar; the cap and rebar shall be described for its material, dimensions, and stamp (need District Survey Coordinator pre-approval).*

## **TxDOT Easement**

The red orange plastic 1 ¾-inch cap stamped "TXDOT EASEMENT" for a 5/8-inch rebar is to indicate a TxDOT easement corner. These corners are typical drainage easements. (see Figure 8). The markers will be typically used by TxDOT Survey Staff. Consultant surveyors can use company caps.



*Figure 8 Example TxDOT Easement Marker.*

## **TxDOT Reference Marker**

The yellow plastic 1 ¾-inch cap stamped "TXDOT REFERENCE MARKER" for a 5/8-inch rebar is to indicate a Point of Commencement for a parcel proposed for acquisition. (see Figure 9). The markers will be used by TxDOT Survey Staff. Consultant surveyors can use company caps.



*Figure 9 Example TxDOT Reference Marker.*

## **Section II: Methods for Setting Monuments**

### **Rock Setting**

A disk can be bonded into a drill hole in bedrock for a very stable setting (see Figure 10). A similar setting in a large concrete structure can be used but is more subject to movement over long periods of time. Culvert headwalls are convenient for benchmarks but make poor locations for static GPS occupations.

- A two-part epoxy or other high strength cement is recommended.
- The stem hole shall be drilled.
- A recess should be chiseled for the head.
- As depicted below by the dashed lines on the stem, any of the disks with ferrules or flare legs can be used.

**Stability:** Rock settings are very stable when in bedrock (NGS stability code A if in bedrock, otherwise B, or C)

**Uses:** Benchmarks, project and secondary control points, property corners, ROW markers.

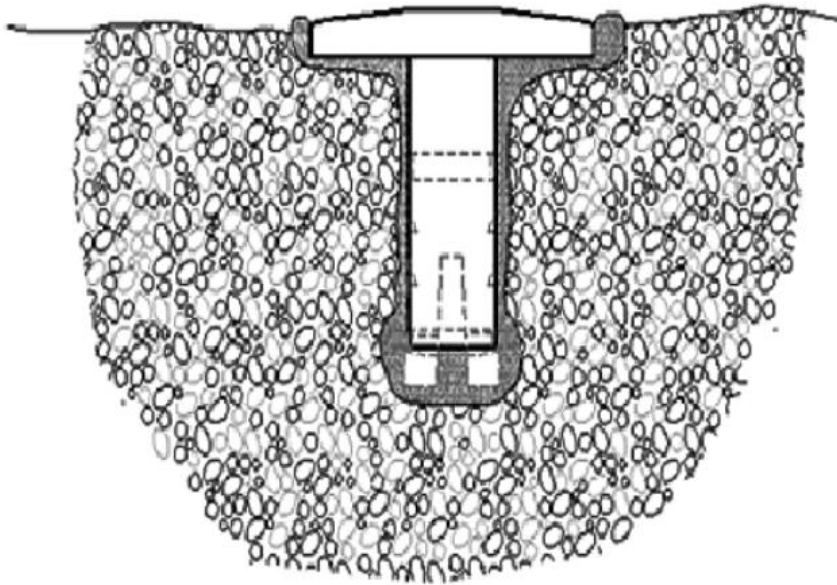

*Figure 10 Example Rock Setting.*

### **Poured Concrete Setting**

A disk placed in a freshly poured concrete post (as shown in Figures 11 and 12) will provide a stable setting.

- It shall be reinforced with either 1/2-inch or 5/8-inch rebar as shown.
- It should be used where it is important to hold the position well.
- Can be countersunk to avoid damage from right of way maintenance

It is shown with the ROW marker but can also be used for control points and benchmarks.

**Stability:** Good (NGS stability code C)

**Uses:** ROW markers, benchmarks and primary control point

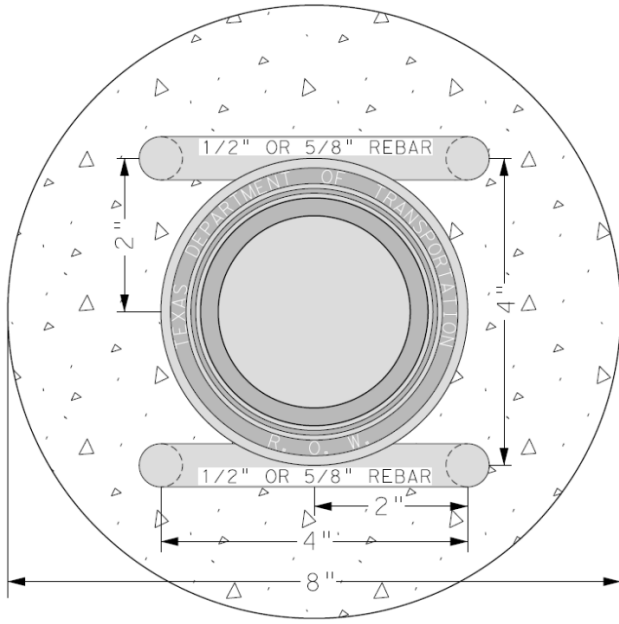

Figure 11 Example Poured Concrete Setting, Top View.

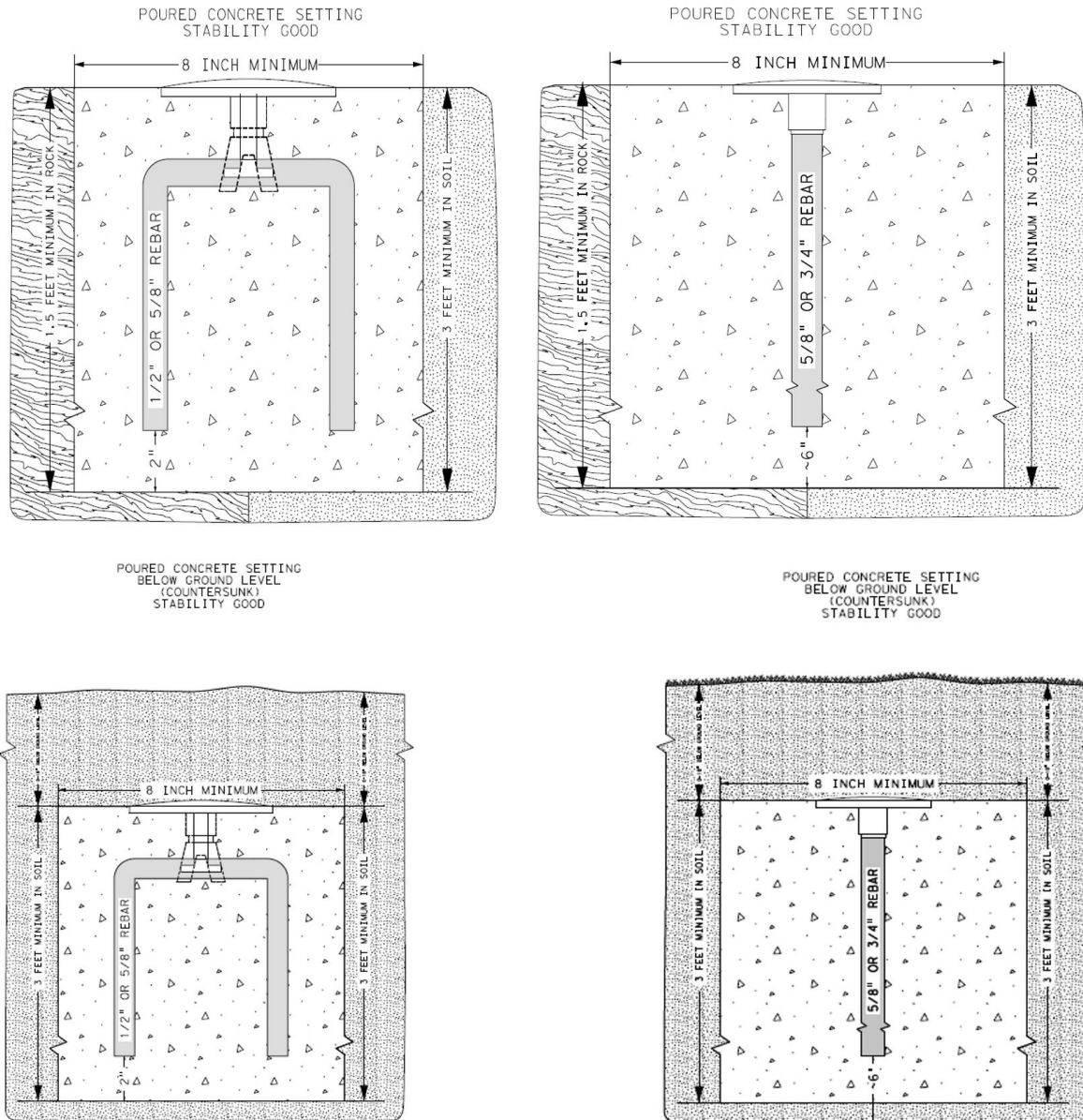

Figure 12 Poured Concrete Setting, Cross Section.

## Datum Point Rod

This is a very stable and secure configuration (see Figures 13 and 14) and should be used whenever possible for major project control points and TxDOT levels 1 and 2 GNSS positions.

- A power driver should be used to drive the rod sections to refusal. However, with proper protection of the rod end, the rod can be hammered into the ground manually.
- This is similar to an NGS Class A rod mark but may include the grease sleeve.

**Stability:** Very good (NGS stability code B)

**Uses:** Benchmarks and control points

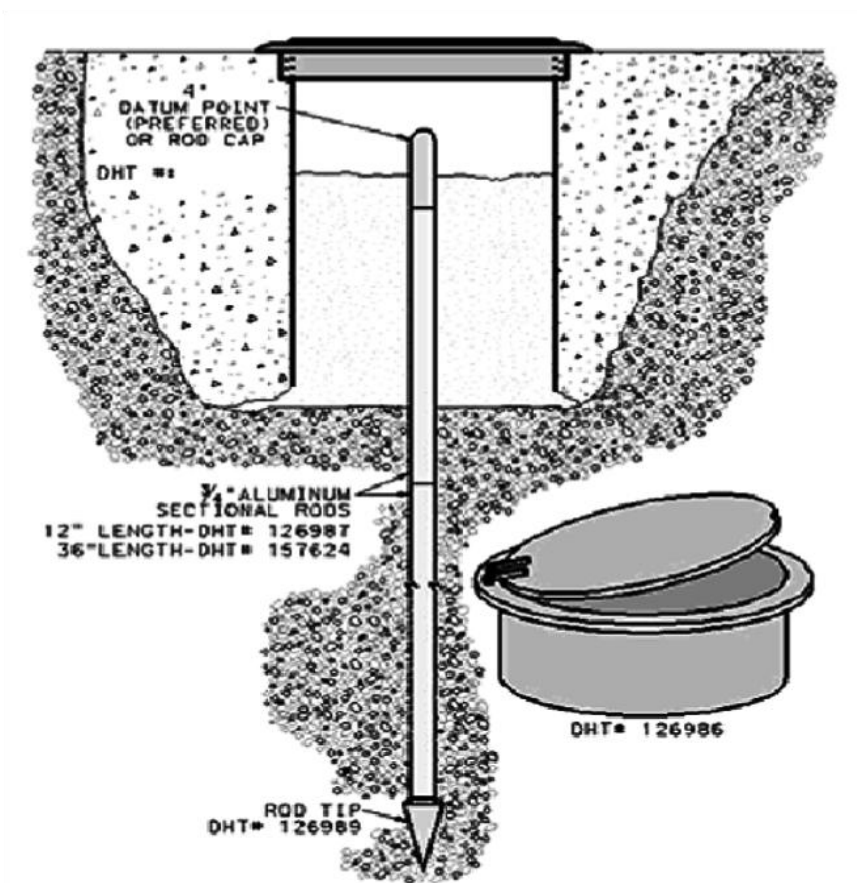

Figure 13 Example Datum Point Rod Setting.



*Figure 14 Example Photo of Datum Point Rod Setting.*

### **Light/Interim Duty Setting**

A cap type marker can be driven onto a minimum length of 12-inches or 18-inches long rebar and set in natural ground (see Figure 15). This is a more economical setting where setting a more stable monument is not justified

- A hole at least 12-inches in rocky soil or 18-inches in loose soil should be dug before driving the rod.
- The rod should be driven to refusal when practical.
- Consult the District Survey Coordinator to determine what circumstances are appropriate for setting this type of monument.

**Stability:** Poor (NGS stability code D)

**Uses:** For secondary survey control

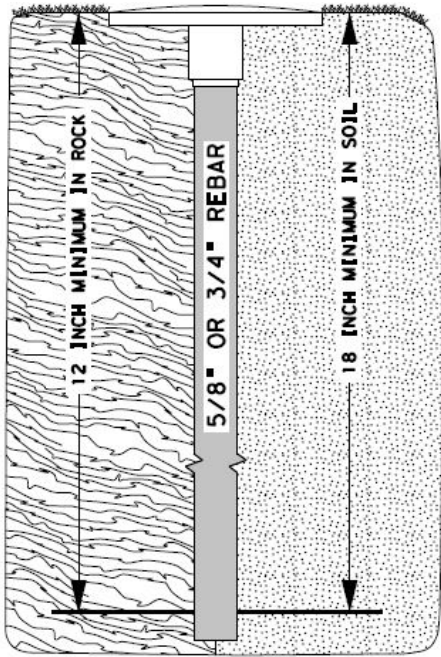

*Figure 15 Light/Interim Duty Setting.*

# Section III: Monument Detail Specification Sheets

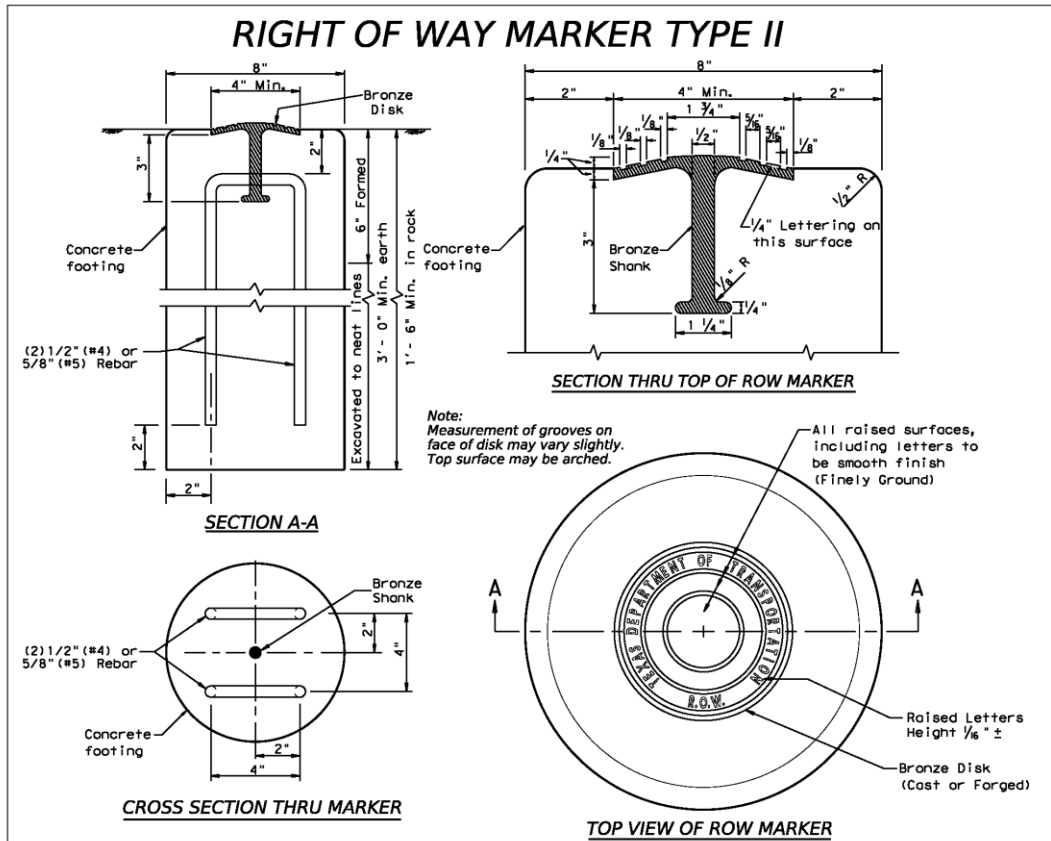

**Note:**  
Measurement of grooves on face of disk may vary slightly. Top surface may be arched.

All raised surfaces, including letters to be smooth finish (Finely Ground)

### GENERAL NOTES

1. All materials and construction shall be in accordance with Item 538, "Right of Way Markers."
2. Right-of-Way marker concrete shall be poured in place. The bronze disks shall be set to the correct line and grade, as directed by the District Survey Coordinator or Engineer.
3. The bronze disk shall be of architectural bronze with the following composition: Copper 85%, Tin 5%, Lead 5%, Zinc 5%. Excavation of the marker locations shall be made of uniform lines except for the top of 6 inches which shall be formed with removable forms. The top part of the marker around the bronze disk shall receive a trowel finish. The bronze disk shall be centered in the top of the concrete (see image "TOP VIEW OF ROW MARKER" above). The monument shall be set at or below ground level.
4. Once the concrete has set, the Registered Professional Land Surveyor either employed by or retained by TxDOT will stencil the required survey data and, with a chisel or center punch, cut across marker the exact location of the Right-of-Way line in the bronze disk.
5. The bronze disk may be substituted for an aluminum cap stamped "TEXAS DEPT. OF TRANSPORTATION ROW MONUMENT" in concrete. See the Monument Specifications document in the Surveyors' Toolkit for more details.

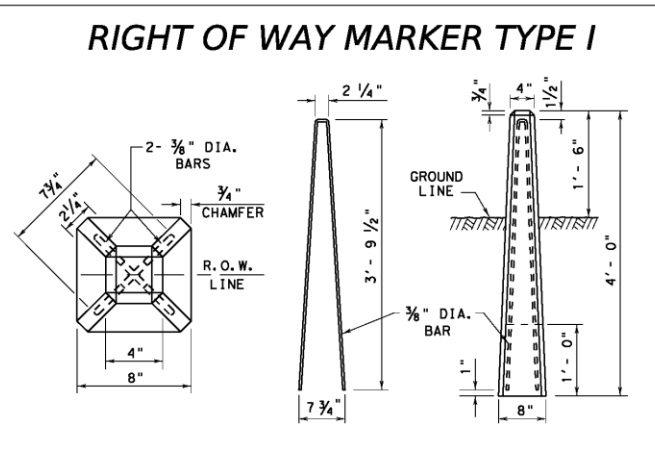

### POURED CONCRETE SETTING BELOW GROUND LEVEL, CROSS SECTION

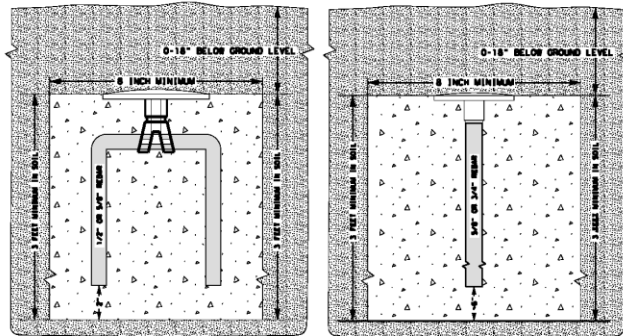

#### ALUMINUM ROW MARKER

R. O. W. MONUMENT

**NOTE:** May be substituted for the Bronze Disk

©TxDOT February 2026

**Texas Department of Transportation**

RIGHT OF WAY DIVISION  
6230 East Stassney Lane  
Austin, Texas 78744  
PHONE: (512) 416-2901

### RIGHT-OF-WAY MARKERS

# TxDOT RIGHT OF WAY TYPE III Monument

The TxDOT Type III Right of Way Monument refers to an intended permanent ROW aluminum cap marker set on rebar driven into natural ground. This includes but is not limited to the aluminum TxDOT Property Corner or the aluminum TxDOT Access Denial caps. This monument is meant to describe permanent (not to be replaced) aluminum capped ROW markers that are set with rebar in soil. The diameter of the cap and its markings are not considered for determining this type. The length and diameter of rebar may vary depending on purpose and soil type.

This monument requires the TxDOT District Registered Professional Land Surveyor (RPLS) pre-approval before use to appropriately determine length and diameter of the rebar. If the TxDOT District does not staff an RPLS, preapproval must be obtained by the ROW Division Survey Section.

Any plastic caps used will be considered interim. Any references to TxDOT Monument Types in proposed parcels for acquisition property descriptions shall always provide a detailed description of the marker material, stamping, and anchor.

When should this monument be considered for use?

- When setting permanent monuments using a rebar as an anchor with an aluminum cap in natural ground.

FOR EXAMPLE: You are tasked with setting property corners for parcels acquired by TxDOT for ROW expansion. You meet with the TxDOT District RPLS and agree to use 18" rebar with a 5/8" diameter and aluminum TxDOT Property Corner cap. You then drive the rebar in the ground countersunk a few inches and cap them accordingly. You have now set a Type III Monument Property Corner.

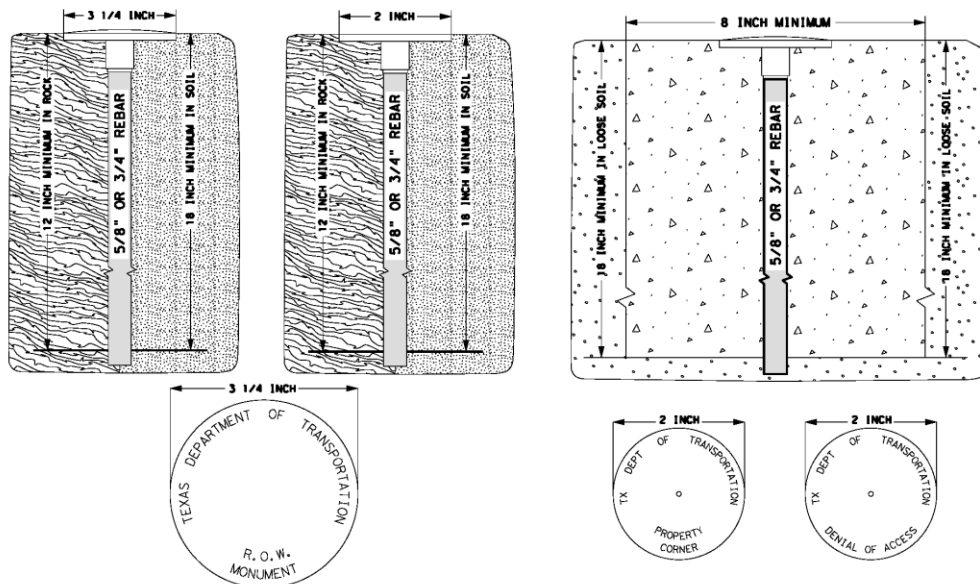

# TxDOT RIGHT OF WAY Interim Monument

The use of Interim/Temporary Right of Way monuments requires the TxDOT District Registered Professional Land Surveyor (RPLS) pre-approval. If the TxDOT District does not staff an RPLS, preapproval must be obtained through the ROW Division Survey Section. The District Survey Coordinator or TxDOT Staff assigned by the District Transportation Planning and Development Director or designee may keep track of project progress and replace the Interim ROW Marker with the Bronze 4" ROW Marker (Type II) during or after project construction.



When should this monument be considered for use?

- When the district has deliberately chosen to set Type II ROW Markers after completion of the project.
- When a Type II ROW Marker cannot be set at a PC, PT, or PI, etc., due to interference or obstruction.
- When there is a lack of permission to set a Type II.

The following statement may be incorporated when setting an Interim ROW monument as the original monument instead of the preferred standard Type II monument.

\*\*\*The monument described and set in this call may be replaced with a TxDOT Type II ROW Marker upon the completion of the highway construction project under the supervision of a Registered Professional Land Surveyor either employed by or retained by TxDOT.\*\*\*

## GENERAL NOTES

1. All materials and construction shall be in accordance with Item 538, "Right of Way Markers."
2. Right-of-Way marker concrete shall be poured in place. The bronze disks shall be set to the correct line and grade, as directed by the District Survey Coordinator or Engineer.
3. The bronze disk shall be of architectural bronze with the following composition: Copper 85%, Tin 5%, Lead 5%, Zinc 5%. Excavation of the marker locations shall be made of uniform lines except for the top 6 inches which shall be secured with removable forms. The top part of the marker around the bronze disk shall receive a trowel finish. The bronze disk shall be centered in the top of the concrete (see image "TOP VIEW OF ROW MARKER" on previous page. The monument shall be set at or below ground level.
4. Once the concrete has set, the Registered Professional Land Surveyor either employed by or retained by TxDOT will stamp the required survey data and, with a chisel or center punch, cut across marker the exact location of the Right-of-Way line on the bronze disk.
5. The bronze disk may be substituted for an aluminum cap stamped "TEXAS DEPT. OF TRANSPORTATION ROW MONUMENT" in concrete. This configuration would be referred to as an aluminum Type II monument. See the Monument Specifications document in the Surveyors' Toolkit for more details.

## SURVEY CONTROL ALUMINUM CAPS FOR REBAR

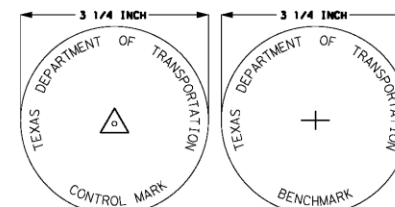

OTxDOT February 2026



RIGHT OF WAY DIVISION  
6230 East Stassney Lane  
Austin, Texas 78744  
PHONE: (512) 416-2901

## RIGHT-OF-WAY MARKERS

**NOT TO SCALE**

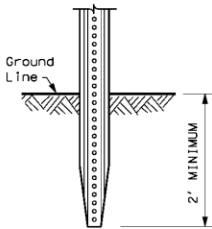
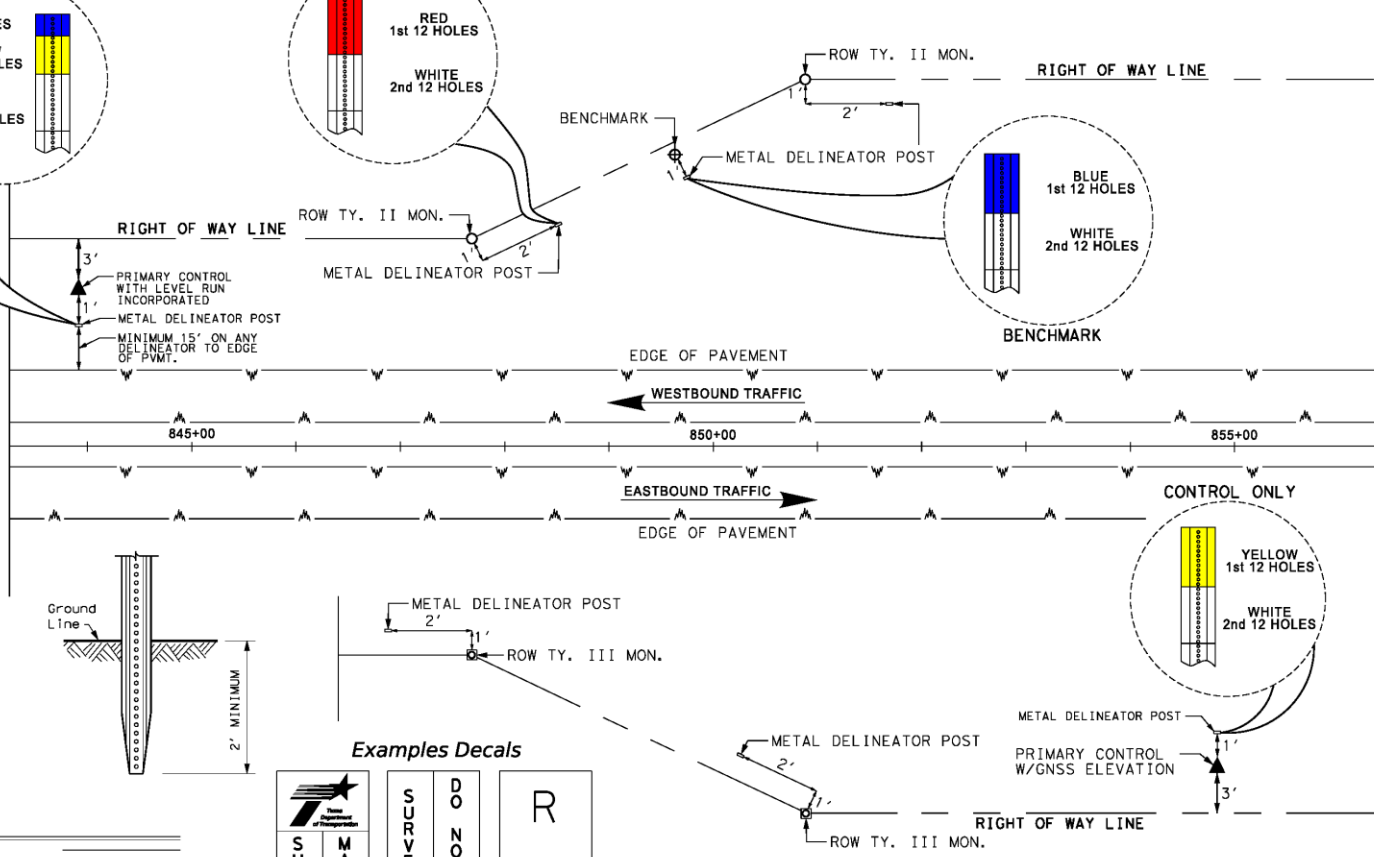
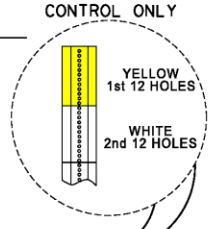
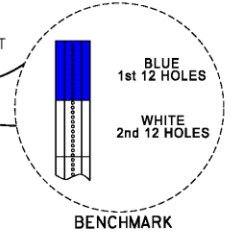
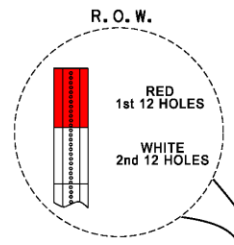
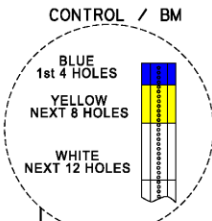

**Examples Decals**

 SURVEY MARKER DO NOT DISTURB <small>For information on this point contact TxDOT at 123-123-1234</small>	SURVEY MARKER DO NOT DISTURB	R O W

*NOTE: The metal delineator post may be substituted for a carsonite marker post and decal at the discretion of the TxDOT District Survey Coordinator or Engineer*

**LEGEND**

- RIGHT OF WAY LINE
- EDGE OF PAVEMENT
- CENTER LINE
- ROW TYPE II MON.
- ROW TYPE III MON.
- METAL DELINEATOR POST
- BENCHMARK
- PRIMARY CONTROL

©TxDOT February 2026

**Texas Department of Transportation**  
 RIGHT OF WAY DIVISION  
 6230 East Stassney Lane  
 Austin, Texas 78744  
 PHONE: (512) 416 - 2901

**DELINEATOR PLACEMENT DETAIL**

