

**AMENDMENT NO. 9 TO
FACILITY CONCESSION AGREEMENT
SH 130, SEGMENTS 5 & 6 FACILITY**

THIS AMENDMENT NO. 9 TO FACILITY CONCESSION AGREEMENT ("Amendment") is entered into and effective as of January 4, 2011 between the Texas Department of Transportation, a public agency of the State of Texas ("TxDOT"), and SH 130 Concession Company, LLC, a Delaware limited liability company ("Developer"), with reference to the following facts:

A. TxDOT and Developer entered into that certain Facility Concession Agreement dated as of March 22, 2007 (the "FCA"), together with related agreements collectively referred to in the FCA as the "FCA Documents". All capitalized terms used but not defined herein shall have the meanings set forth in the FCA.

B. The purpose of this amendment is to make certain corrections to Attachment 10 to the Book 2 Technical Requirements, as set forth below.

For good and valuable consideration, the receipt and sufficiency of which is hereby acknowledged, TxDOT and the Developer agree as follows:

1. Amendment to Attachment 10 of Book 2 Technical Requirements. The color codes listed in Attachment 10 are hereby amended to reflect the following corrections, as further illustrated in Exhibit 1 attached hereto:

Existing color code, Terracotta-Federal Standard I.D. No. 30252 is deleted and replaced with HC117 Silk Chocolate.

Existing color code, Buff-Federal Standard I.D. No. 33711 is deleted and replaced with HC136 Aztec Sand.

2. Effectiveness of FCA Documents. Except as specifically amended hereby, the provisions of the FCA Documents, as previously amended by Amendments 1 - 8, are hereby confirmed without change.

3. Binding Effect of Amendment. This Amendment is entered into pursuant to Section 24.3 of the FCA, and shall be valid, effective and enforceable.

4. Counterparts. This Amendment may be executed in multiple counterparts, each of which shall be fully effective as an original and all of which together shall constitute one and the same instrument.

IN WITNESS WHEREOF, the parties have caused this Amendment to be duly executed as of the day and year first above written.

Developer

TxDOT

SH 130 CONCESSION COMPANY LLC

TEXAS DEPARTMENT OF TRANSPORTATION

By: 

Name: Javier Gutierrez

Title: Chief Executive Officer

By: 

Name: Steven E. Simmons

Title: Deputy Executive Director

EXHIBIT 1

REV	DATE	BY	DESCRIPTION
0	07/11/2008		APPROVED FOR CONST

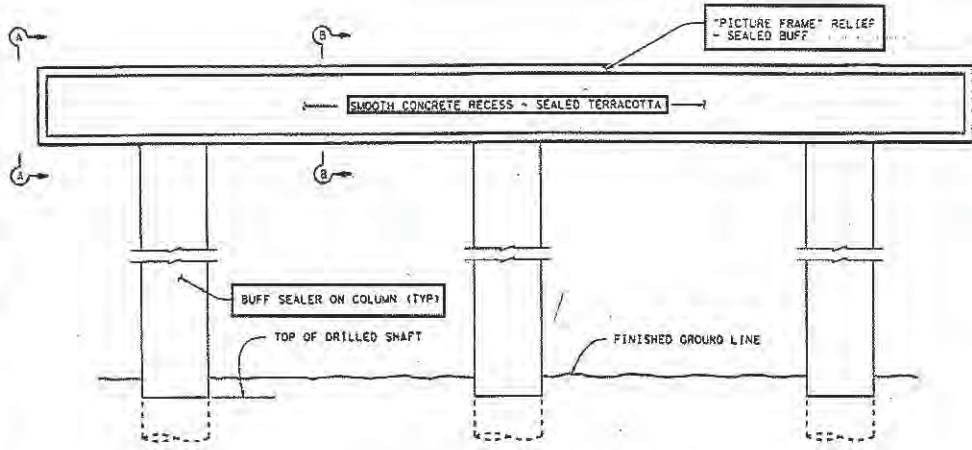

ELEVATION ~ ROUND COLUMNS

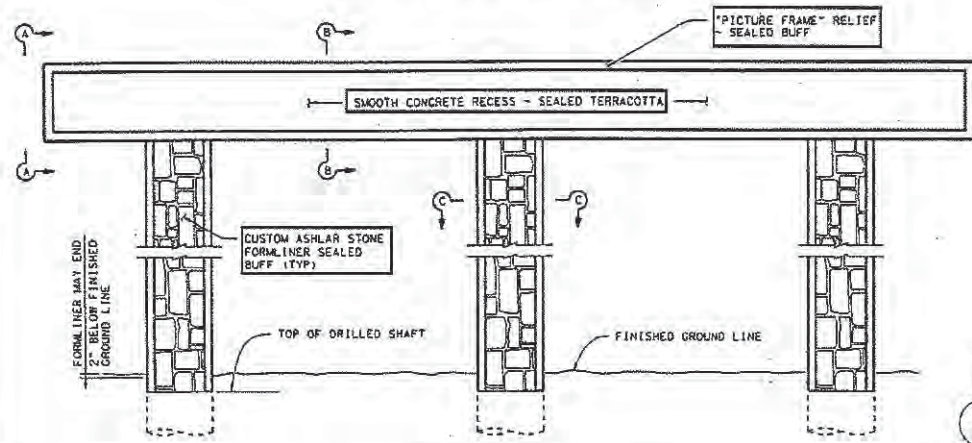

ELEVATION ~ SQUARE COLUMNS

- GENERAL NOTES:
1. CHAMFER ALL EXPOSED CAP EDGES $\frac{3}{4}$ "
 2. FOR ASHLAR STONE FORM LINER DETAILS SEE AEST1(SPL11BRS-109) SHEET.
 3. THE TERRACOTTA SEALER SHALL CONFORM TO THE FEDERAL STANDARD COLOR I.D. NO. 30252.
 4. THE BUFF SEALER SHALL CONFORM TO THE FEDERAL STANDARD COLOR I.D. NO. 33711.
 5. SEALER SHALL NOT BE APPLIED TO THE BEARING SEATS.

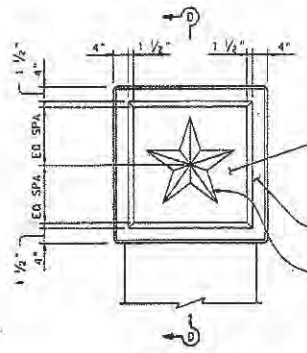

SECTION A-A
SHOWING ROUND COLUMN

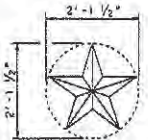

STAR DETAIL
1 1/2" RAISED STAR MOTIF
INSCRIBED BY A 2'-1 1/2"
DIAMETER CIRCLE.

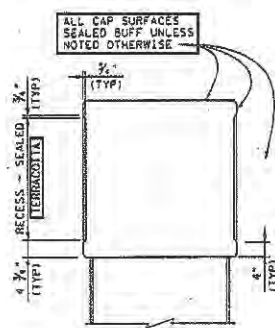

SECTION B-B
SHOWING SQUARE COLUMN

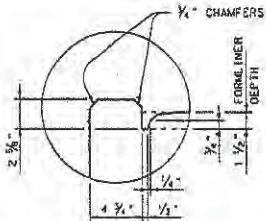

CUSTOM ASHLAR
FORMLINER DETAIL

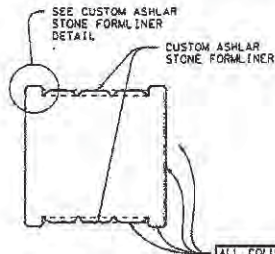

SECTION C-C

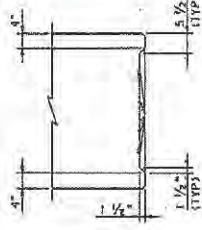

SECTION D-D

BRIDGEFARMER & ASSOCIATES, INC.
CONSULTING ENGINEERS
Approved:
The DGM certifies that this submittal has been through the Design QC/QA process and meets the LSI approved Design QC/QAR
Approved except as noted: See Design Exception Letter No. _____
Design Quality Assurance Manager
Mansoor Arifin, P.E.



TEXAS DEPARTMENT OF TRANSPORTATION
AESTHETIC DETAILS
MULTI-COLUMN BENT
AEST1 (SPL)

SHEET 1 OF 1

DESIGNED BY	ENCLERD BY	DATE	07-13-08
DRAWN BY	ENCLERD BY	DATE	
APPROVED BY	DATE	PROJECT NO.	
PERI FOR A10 PROJECT NO.	SHEET NAME	DWG NO.	
6	B6-2X08001	BR3-100	
STATE	DISTRICT	COUNTY	
TX	AUS		
CONF	SECT	JOB	RIGHTWAY NO. CUTWAY

Terracotta-Federal Standard I.D. No. 30252 shall be replaced with HC117 Silk Chocolate.
Buff-Federal Standard I.D. No. 33711 shall be replaced with HC136 Aztec Sand.

REV	DATE	BY	DESCRIPTION
0	02/11/2008		APPROVED FOR CONST

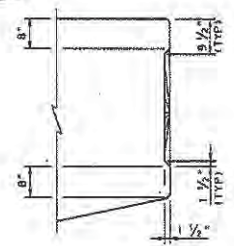
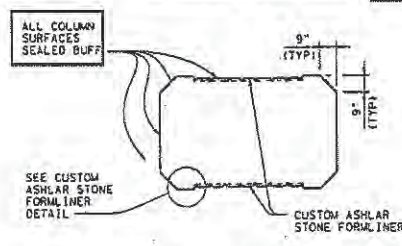
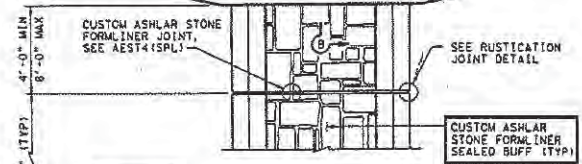
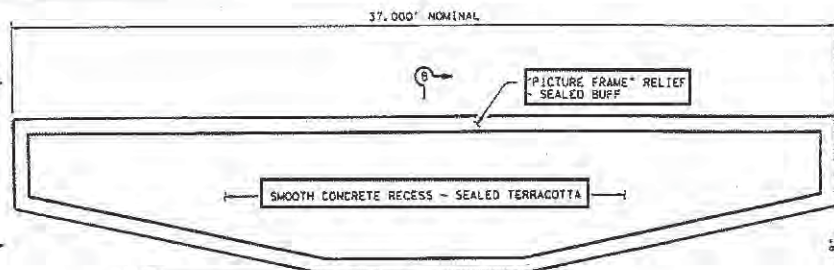

SECTION C-C

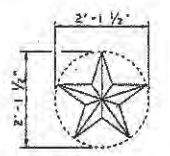

STAR DETAIL
1 1/2" RAISED STAR MOTIF
INSCRIBED BY A 2'-1 1/2"
DIAMETER CIRCLE.

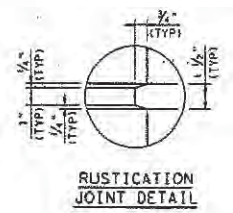

RUSTICATION
JOINT DETAIL

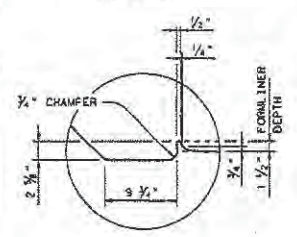

CUSTOM ASHLAR
FORMLINER DETAIL

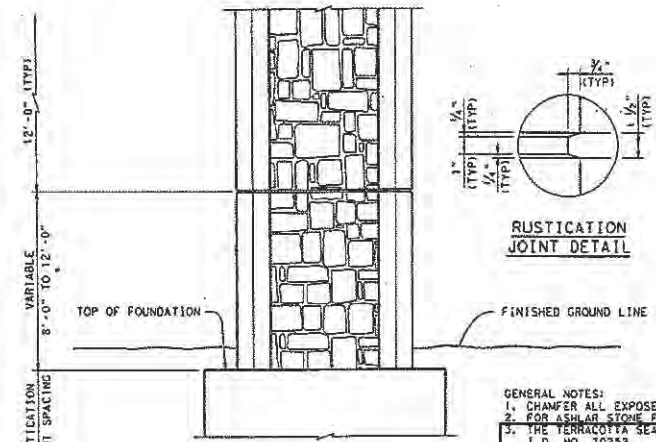

ELEVATION

- GENERAL NOTES:
1. CHAMFER ALL EXPOSED CAP EDGES 3/4".
 2. FOR ASHLAR STONE FORMLINER DETAILS SEE AEST1(5PL) (BRS-108) SHEET.
 3. THE TERRACOTTA SEALER SHALL CONFORM TO THE FEDERAL STANDARD COLOR I.D. NO. 30252.
 4. THE BUFF SEALER SHALL CONFORM TO THE FEDERAL STANDARD COLOR I.D. NO. 33711.
 5. SEALER SHALL NOT BE APPLIED TO THE BEARING SEATS.

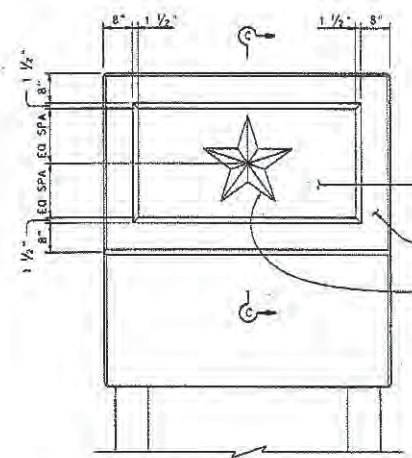

SECTION A-A

ALL CAP SURFACES SEALED BUFF
UNLESS NOTED OTHERWISE

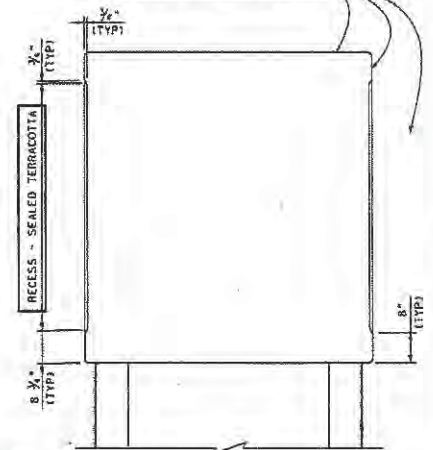

SECTION B-B

BRIDGEFARMER & ASSOCIATES, INC.
CONSULTING ENGINEERS
Approved:
The DOAM certifies that this submittal has been through the Design QC/QA process and meets the LSI approved Design QC/QAR.
Approved except as noted: See Design Exception Letter No. _____
William A. ...
Design Quality Assurance Manager
Mansoor Alshayq, P.E.

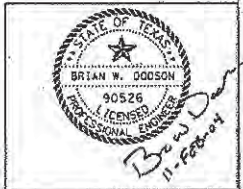

©2004
TEXAS DEPARTMENT OF TRANSPORTATION
AESTHETIC DETAILS
37 FT - HAMMER HEAD BENT
AEST2(5PL)

SHEET 1 OF 1

DESIGNED BY	CHECKED BY	DATE	23-11-23
DRAWN BY	PROJECT #	SCALE	
PROJECT BY	REV	PROJECT NO.	
FED. AID PROJECT NO.	SHEET NAME	DWG NO.	
6	SS-2X20B001	BRS-101	
STATE	DISTRICT	COUNTY	
TX	AUS		
CONTRACT	SECTION	JOB	REVISION NO.

Terracotta-Federal Standard I.D. No. 30252 shall be replaced with HC117 Silk Chocolate.
Buff-Federal Standard I.D. No. 33711 shall be replaced with HC136 Aztec Sand.

REV	DATE	BY	DESCRIPTION
0	12/11/2007		APPROVED FOR CONSTRUCTION

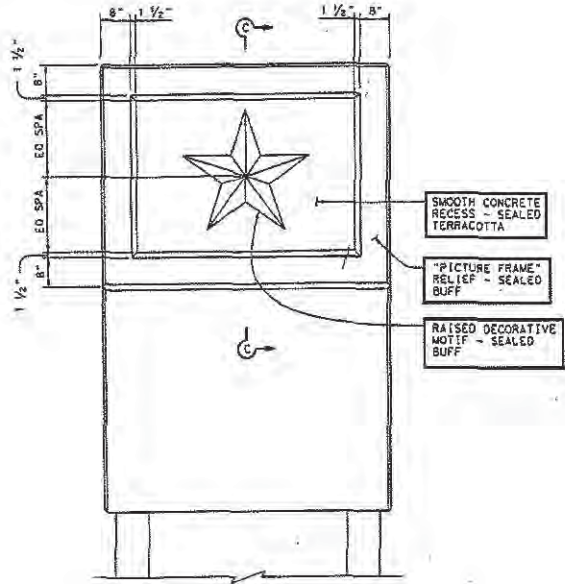

SECTION A-A

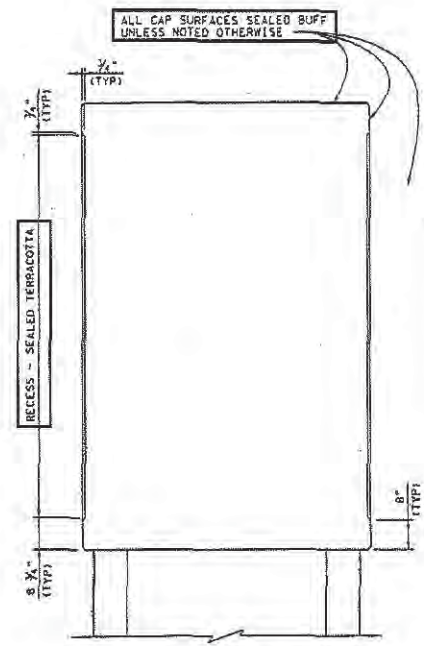

SECTION B-B

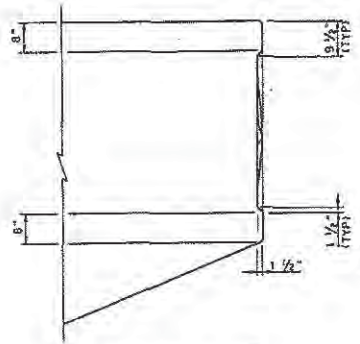

SECTION C-C

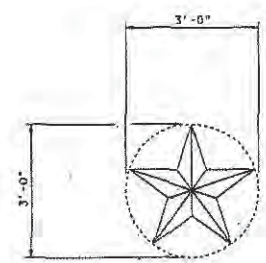

STAR DETAIL
1 1/2" RAISED STAR MOTIF
INSCRIBED BY A 3'-0"
DIAMETER CIRCLE.

Terracotta-Federal Standard I.D. No. 30252 shall be replaced with HC117 Silk Chocolate.
Buff-Federal Standard I.D. No. 33711 shall be replaced with HC136 Aztec Sand.

BRIDGEFARMER & ASSOCIATES, INC.
CONSULTING ENGINEERS

Approved
The DCMA certifies that this submittal has been through the Design QC/QA process and meets the LSI approved Design QC/QA.

Approved except as noted: See Design Exception Letter No. _____

W. Mansoor Khan
Design Quality Assurance Manager
Mansoor Khan, P.E.



©2004
TEXAS DEPARTMENT OF TRANSPORTATION
AESTHETIC DETAILS
57 FT - HAMMER HEAD BENT
AEST3 (SPL)

SHEET 2 OF 2

DESIGNED BY	DATE	03-03-03
DRAWN BY	DATE	
CHECKED BY	DATE	
PROJECT NO.	SHEET NO.	
88-2XVDB007	88-103	
STATE	DISTRICT	COUNTY
TX	AUS	
CONTRACT NO.	SECTION	JOB NO.
		DESIGN NO.
		SH130

REV.	DATE	BY	DESCRIPTION
5	02/11/2020		APPROVED FOR CONST.

BRIDGFARMER & ASSOCIATES, INC.
CONSULTING ENGINEERS
Approved:
The DQAS certifies that this submittal has been through the Design QC/QA process and meets the LSI approved Design QC/QA.
Approved except as noted: See Design Exception Letter No. 02/17/20
Design Quality Assurance Manager
Margaret Allison, P.E.

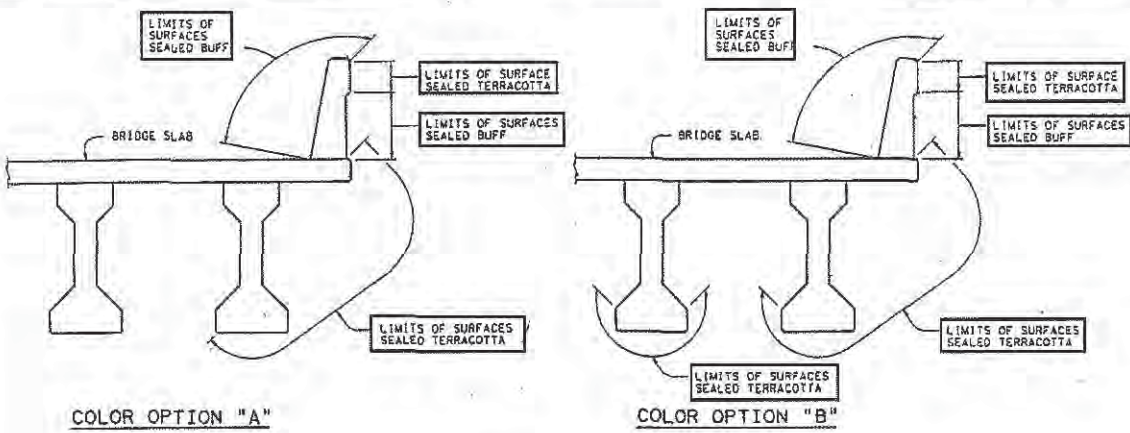

COLOR OPTION "A"

COLOR OPTION "B"

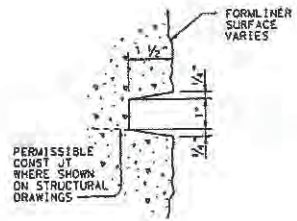

DETAIL A

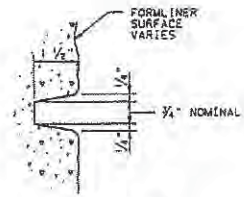

DETAIL B

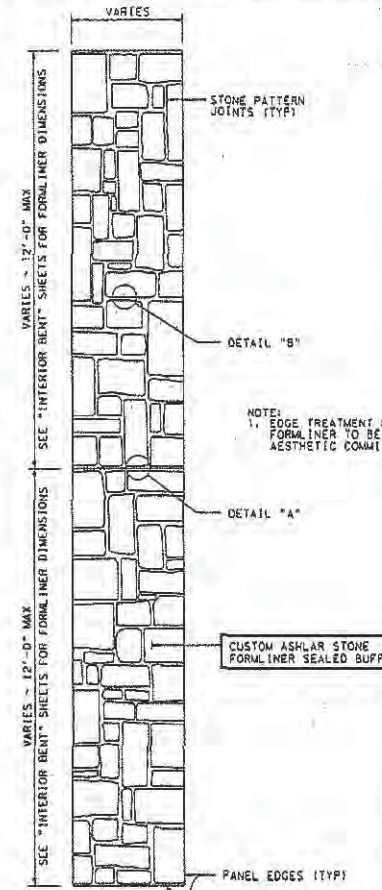

CUSTOM ASHLAR STONE FORMLINER-PANEL FOR BENTS AND SIGN BRIDGE COLUMNS

NOTE:
1. EDGE TREATMENT FOR ASHLAR FORMLINER TO BE APPROVED BY AESTHETIC COMMITTEE CHAIRMAN.

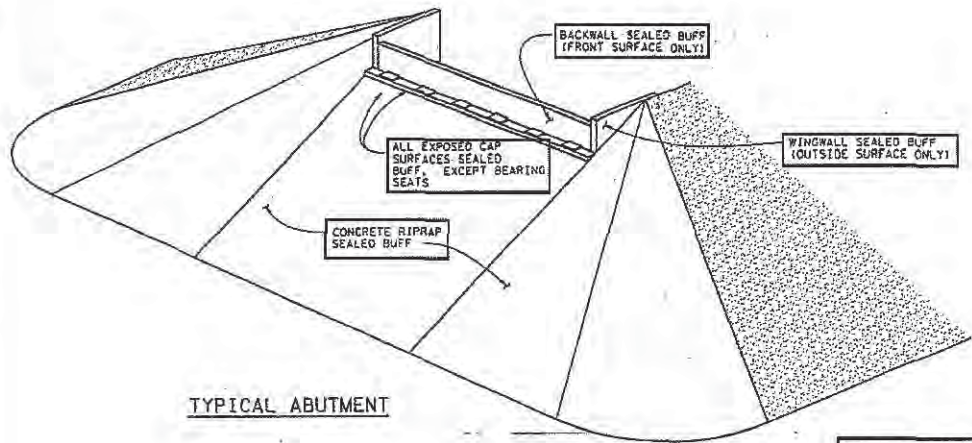

TYPICAL ABUTMENT

- GENERAL NOTES:
1. THE FABRICATOR SHALL NOT SPLICE, CUT AND JOIN, OR GLUE THE FORMLINER PANELS TOGETHER, EACH PANEL SHALL BE FABRICATED TO FORM A ONE PIECE UNIT TO THE SIZE AND SPECIFICATIONS SET FORTH IN THE PLAN SHEETS. FORMLINERS SHALL BE WASHED AND CLEANED AFTER EACH USE. FORMLINERS THAT HAVE BECOME DAMAGED OR WORN SHALL BE REPLACED BY THE CONTRACTOR.
 2. ALL FORMLINER SURFACES SHALL RECEIVE A SURFACE AREA 1 CLASS B FINISH USING OPAQUE CONCRETE SEALER AS NOTED IN SPECIAL PROVISION.
 3. ALL FORMLINER PANEL JOINTS SHALL BE SEALED IN A MANNER ACCEPTABLE TO THE ENGINEER, TO PREVENT LEAKAGE AT THE SURFACE UPON CASTING OF CONCRETE.
 4. CHAMFER ALL EXPOSED CAP EDGES 3/4\"/>

Terracotta-Federal Standard I.D. No. 30252 shall be replaced with HC117 Silk Chocolate.
Buff-Federal Standard I.D. No. 33711 shall be replaced with HC136 Aztec Sand.



AESTHETIC DETAILS
MISCELLANEOUS DETAILS
AEST(5PL)

SHEET 1 OF 1

DESIGNED BY:	CREATED BY:	AUTO
DRAWN BY:	CHECKED BY:	DATE:
APPROVED BY:	DATE:	PROJECT NO.:
PROJECT NO. AND PRODUCT NO.	SHEET NAME:	SHEET NO.
61-B6-2XX08001	BAS-108	10
STATE:	DISTRICT:	COUNTY:
TX	AUS	
CONTRACT:	SECTION:	JOB:
		HIGHWAY AND
		SECTION:

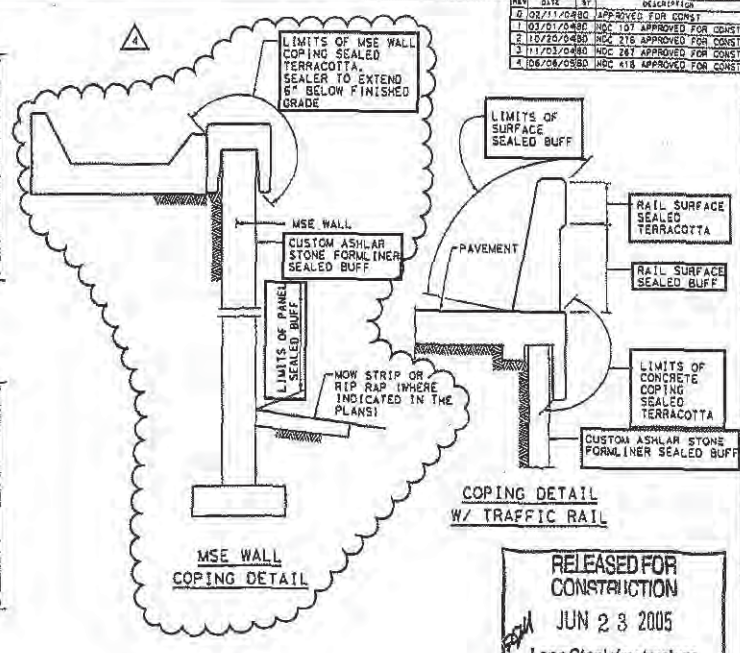
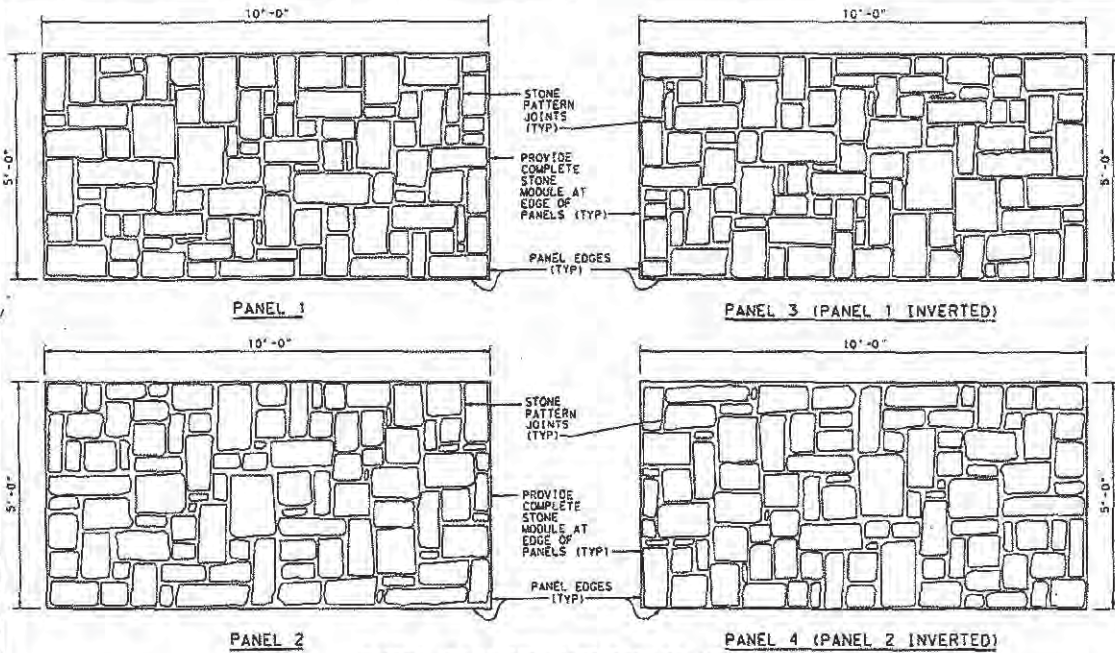

REV.	DATE	BY	DESCRIPTION
1	02/11/2000		APPROVED FOR CONST.
2	03/01/2000		ADC 101 APPROVED FOR CONST.
3	10/20/2000		ADC 276 APPROVED FOR CONST.
4	11/03/2000		ADC 347 APPROVED FOR CONST.
5	08/04/2000		ADC 418 APPROVED FOR CONST.

CUSTOM ASHLAR FORMLINER FOR MSE AND CIP WALLS

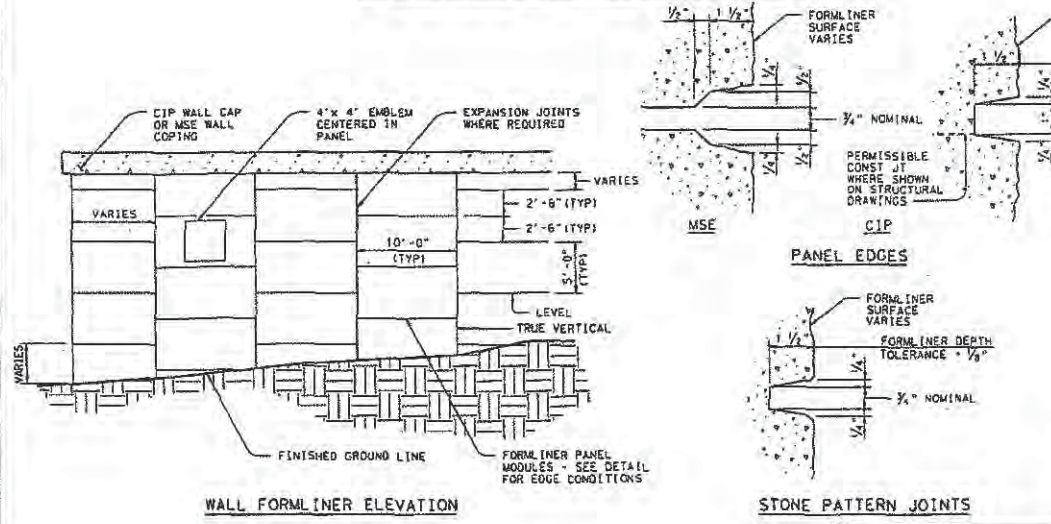

- GENERAL NOTES:**
1. THE FABRICATOR SHALL NOT SPLICE, CUT AND JOIN, OR GLUE THE FORMLINER PANELS TOGETHER. EACH PANEL SHALL BE FABRICATED TO FORM A ONE PIECE UNIT TO THE SIZE AND SPECIFICATIONS SET FORTH IN THE PLAN SHEETS. FORMLINERS THAT HAVE BECOME DAMAGED OR WORN SHALL BE REPLACED BY THE CONTRACTOR.
 2. ALL FORMLINER SURFACES SHALL RECEIVE A SURFACE AREA 1, CLASS B FINISH USING OPAQUE CONCRETE SEALER AS NOTED IN SPECIAL PROVISION.
 3. ALL FORMLINER PANEL JOINTS SHALL BE SEALED IN A MANNER ACCEPTABLE TO THE ENGINEER OF RECORD, TO PREVENT LEAKAGE AT THE SURFACE UPON CASTING OF CONCRETE.
 4. PANEL DIMENSIONS INDICATED ARE NOMINAL AND SUBJECT TO FINAL APPROVAL OF THE ENGINEER OF RECORD.
 5. AN APPROXIMATELY EQUAL NUMBER OF PANELS SHALL BE PRODUCED AND RANDOMLY PLACED ON THE RETAINING WALL. CARE SHOULD BE TAKEN TO AVOID:
 - IN WALLS COMPOSED OF A NON-STAGGERED SINGLE ROW OF PANELS, NO TWO ADJACENT HORIZONTAL PANELS SHALL BE OF THE SAME (ASHLAR STONE PATTERN) TYPE.
 - IN WALLS CONTAINING MULTIPLE ROWS OF STAGGERED PANELS, NO TWO FULL SIZE VERTICALLY ADJACENT PANELS INCORPORATED IN THE SAME VERTICAL PANEL BAY (OR LINE) SHALL BE OF THE SAME (ASHLAR STONE PATTERN) TYPE.
 DEVIATIONS TO THIS PANEL PLACEMENT PROTOCOL ARE SUBJECT TO THE APPROVAL OF TxDOT.
 6. CHAMFER ALL EXPANDED CAP EDGES 1/4".
 7. THE TERRA COTTA SEALER SHALL CONFORM TO THE FEDERAL STANDARD COLOR I.D. NO. 30252.
 8. THE BUFF SEALER SHALL CONFORM TO THE FEDERAL STANDARD COLOR I.D. NO. 33711.
 9. CORNER ELEMENTS FOR THIS PROJECT SHALL HAVE A PLAIN SMOOTH FINISH. PANELS WILL BE CAST WITH NON-COLORED CONCRETE AND WILL NOT RECEIVE A SANDBLAST TREATMENT.

RELEASED FOR CONSTRUCTION
JUN 23 2005
Lone Star Infrastructure

STATE OF TEXAS
BRIAN W. DOOSON
90526
LICENSED PROFESSIONAL ENGINEER
Brewster
6/23/05
TEAM MEMBER
DOOSON/STARR

TEXAS DEPARTMENT OF TRANSPORTATION
AESTHETIC DETAILS
CUSTOM ASHLAR FORMLINER
AESTS(SPL)

SHEET 1 OF

DESIGNED BY	CHECKED BY	DATE
DRWEN BY PMS	CRISTINA P. BO	05/05/05
APPROVED BY PMS	DATE	PROJECT NO.
FED/ AEC ADO PROJECT NO.	SHEET NAME	DWG NO.
B. 65-2XKDB001	BRS-110	
STATE	DISTRICT	COUNTY
TX	AUS	
CONT	SECT	JOB
		HIGHWAY NO.
		SHT 30

Terracotta-Federal Standard I.D. No. 30252 shall be replaced with HC117 Silk Chocolate.
Buff-Federal Standard I.D. No. 33711 shall be replaced with HC136 Aztec Sand.

REV	DATE	BY	DESCRIPTION
0	05/21/04SD		APPROVED FOR CONST

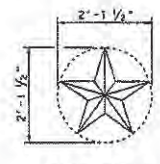
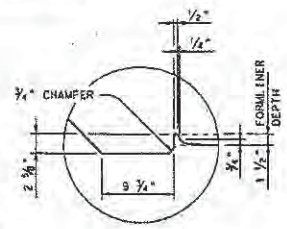
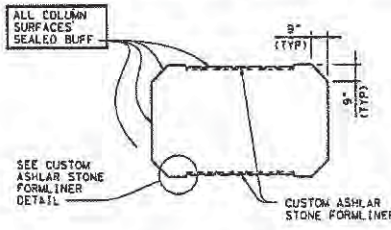
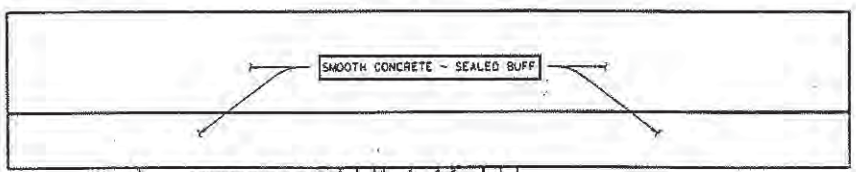

STAR DETAIL
 1 1/2" RAISED STAR MOTIF
 INSCRIBED BY A 2'-1 1/2"
 DIAMETER CIRCLE.

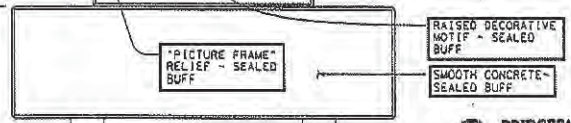
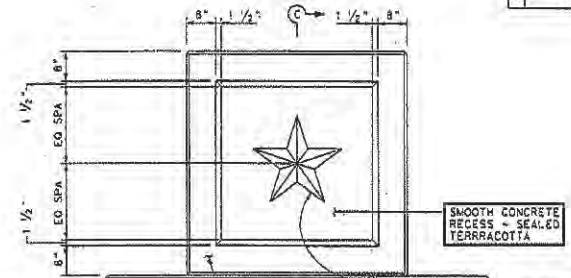

BRIDGEFARMER & ASSOCIATES, INC.
 CONSULTING ENGINEERS
 Approved:
 The O&M certifies that this submittal has been through the Design QC/QA process and meets the LSI approved Design QC/QA.
 Approved except as noted: See Design Exception Letter No. *02/14/04*
 Design Quality Assurance Manager
 Mansoor Akhavan



TEXAS DEPARTMENT OF TRANSPORTATION
 AESTHETIC DETAILS
 INVERTED TEE BENT
 AEST6 (SPL)

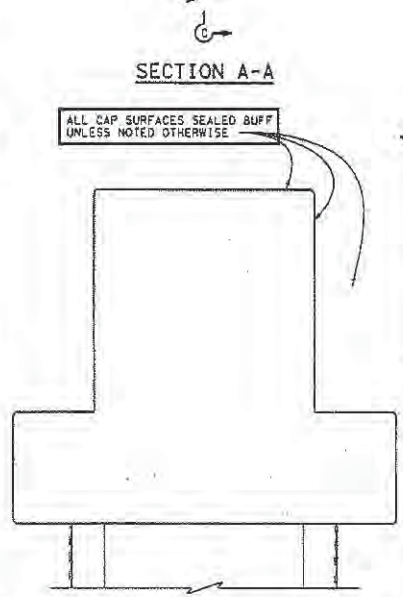
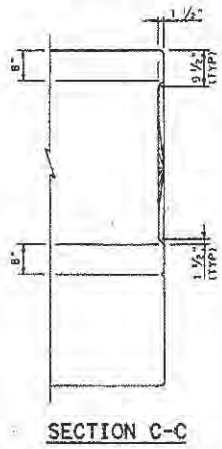
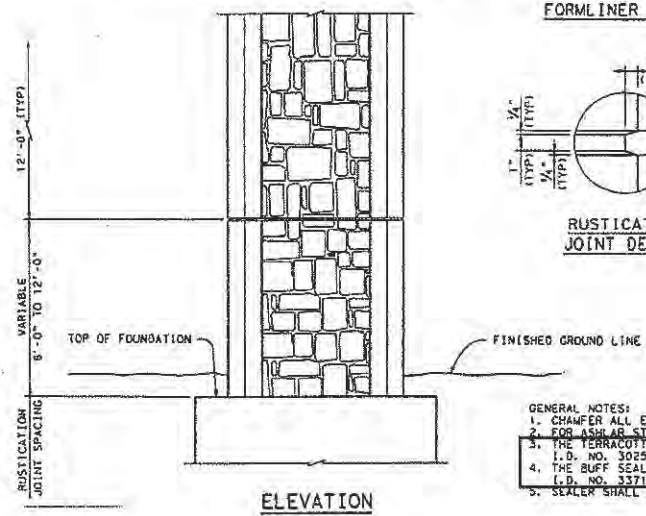

- GENERAL NOTES:**
1. CHAMFER ALL EXPOSED CAP EDGES 3/4".
 2. FOR ASHLAR STONE EDGM. LINER DETAILS SEE AEST4 (SPL) BRSS-1041 SHEET.
 3. THE TERRACOTTA SEALER SHALL CONFORM TO THE FEDERAL STANDARD COLOR I.D. NO. 30252.
 4. THE BUFF SEALER SHALL CONFORM TO THE FEDERAL STANDARD COLOR I.D. NO. 33711.
 5. SEALER SHALL NOT BE APPLIED TO THE BEARING SEATS.

Terracotta-Federal Standard I.D. No. 30252 shall be replaced with HC117 Silk Chocolate.
 Buff-Federal Standard I.D. No. 33711 shall be replaced with HC136 Aztec Sand.

SHEET 1 OF 1

REVISED BY	NO.	DATE	BY	DATE

DESIGNED BY	CHECKED BY	DATE

PROJECT NO.	PROJECT NAME	SHEET NAME	DATE
6 SE-2XX08001	BRS-104		

STATE	DISTRICT	COUNTY
TX	AUS	

CONTRACT	SECTION	JOB	HIGHWAY NO.

REV	DATE	BY	DESCRIPTION
2	03/28/04	MD	APPROVED FOR CDMS
1	03/12/04	MD	APPROV FOR CONST
3	05/05/04	MD	NDC 182 APPROV FOR CONST

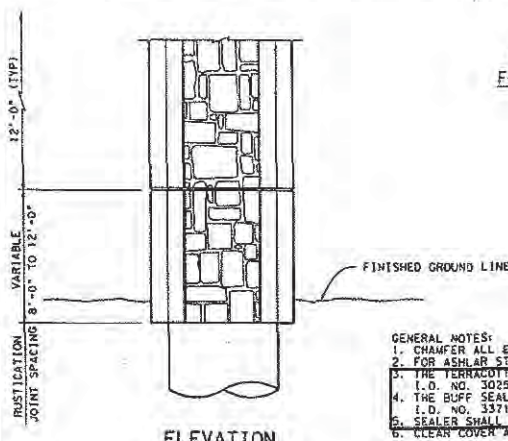
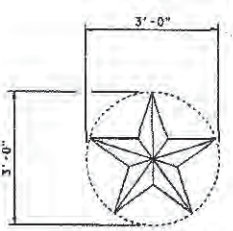
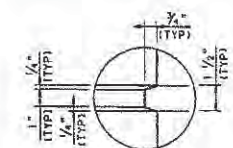
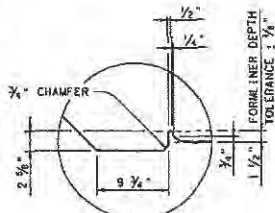
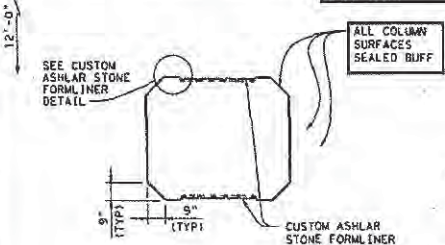
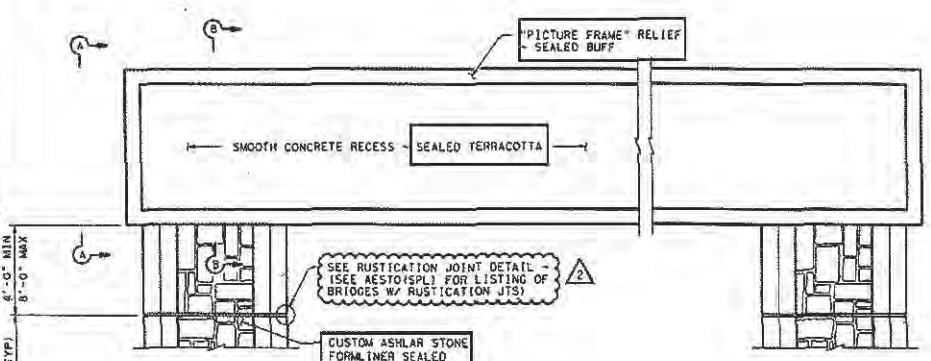

- GENERAL NOTES:**
1. CHAMFER ALL EXPOSED CAP EDGES 3/4".
 2. FOR ASHLAR STONE FORMLINER DETAILS SEE AEST4(SPL) (BRS-100) SHEET
 3. THE TERRACOTTA SEALER SHALL CONFORM TO THE FEDERAL STANDARD COLOR I.D. NO. 30252.
 4. THE BUFF SEALER SHALL CONFORM TO THE FEDERAL STANDARD COLOR I.D. NO. 33711.
 5. SEALER SHALL NOT BE APPLIED TO THE BEARING SEATS.
 6. CLEAR COVER AT CUSTOM ASHLAR FORMLINER MAY VARY TO A MINIMUM OF 1/8".
 7. CLEAR COVER AT RUSTICATION JOINT SHALL BE A MINIMUM OF 2".

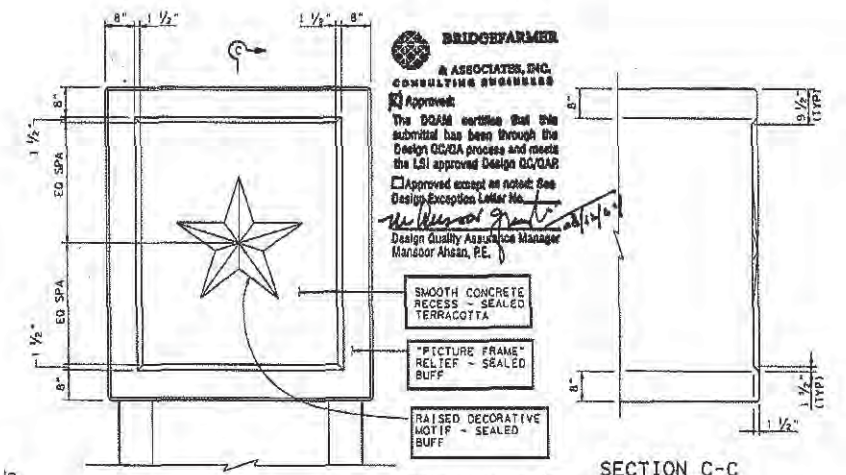

BRIDGEFARMER & ASSOCIATES, INC.
CONSULTING ENGINEERS

Approved:
The DCAM certifies that this submittal has been through the Design QC/QA process and meets the LSI approved Design QC/QA.

Approved except as noted: See Design Exception Letter No. *MD 04/14/04*

Design Quality Assurance Manager
Mansoor Ahsan, P.E.

RELEASED FOR CONSTRUCTION
MAY 12 2004
LoneStar Infrastructure

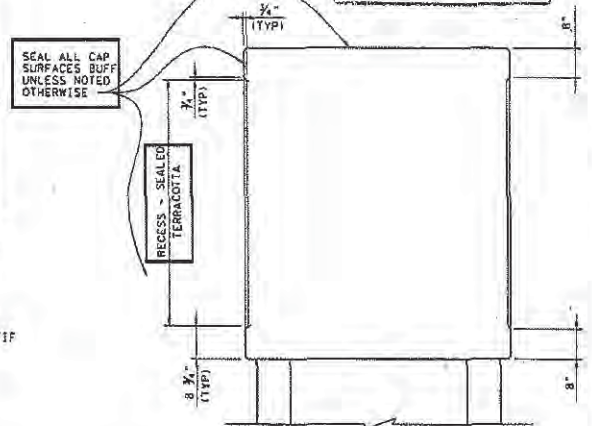

STATE OF TEXAS
BRIAN W. DODSON
90526
LICENSED PROFESSIONAL ENGINEER

5-MAY-04

TEXAS DEPARTMENT OF TRANSPORTATION
AESTHETIC DETAILS
STRADDLE BENT
AEST7(SPL)

SHEET 1 OF 1

DESIGNED BY: MD	CHECKED BY:	DATE: 03-01-04
DRAWN BY: MD	CHECKED BY:	DATE: 03-01-04
APPROVED BY: MD	DATE:	PROJECT NO:
FED PROJ AID PROJECT NO:	SHEET NAME:	DWG NO:
6 86-2XX0001	BRS-105	
STATE:	DISTRICT:	COUNTY:
TX	ALIS	
CONTRACT NO.:	SECTION:	JOB:
		HIGHWAY NO.:

Terracotta-Federal Standard I.D. No. 30252 shall be replaced with HC117 Silk Chocolate.
Buff-Federal Standard I.D. No. 33711 shall be replaced with HC136 Aztec Sand.

REV#	DATE	BY	DESCRIPTION
0	03/25/2004	ABAC	APPROVED FOR CONST
1	03/22/2008	MDC	STR ETC
2	02/01/2008	MDC	993 A/C

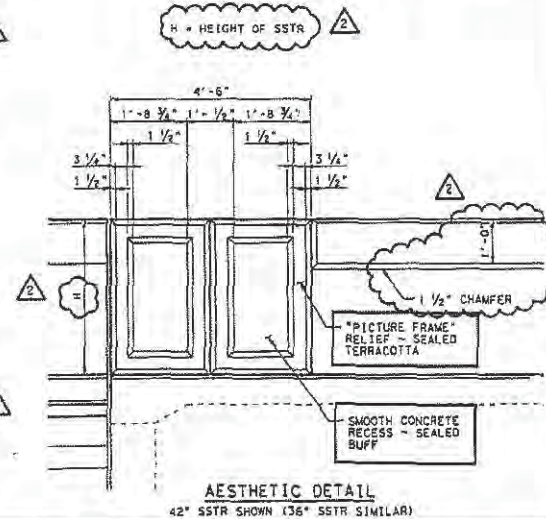
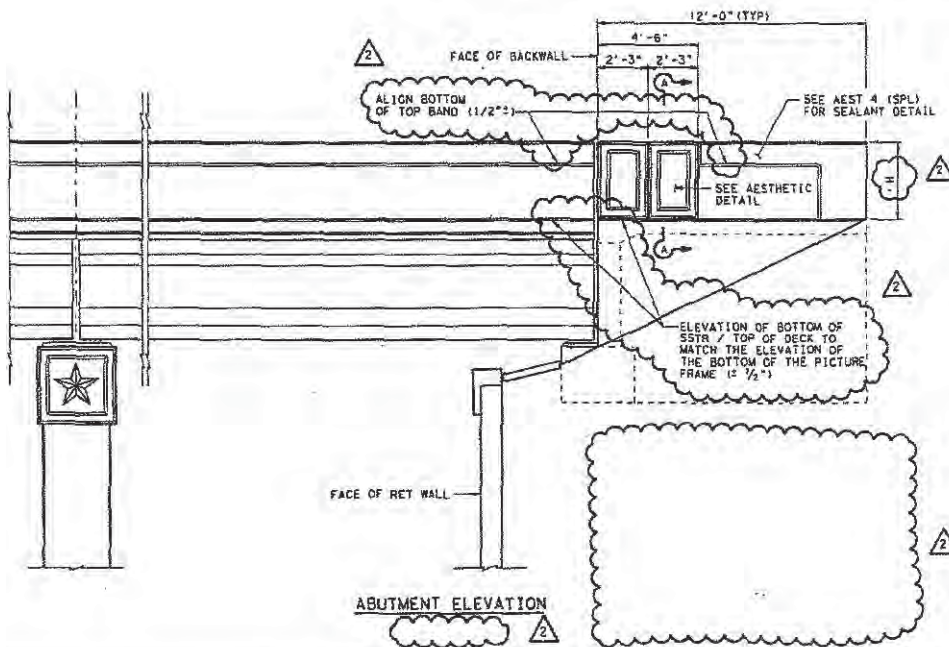
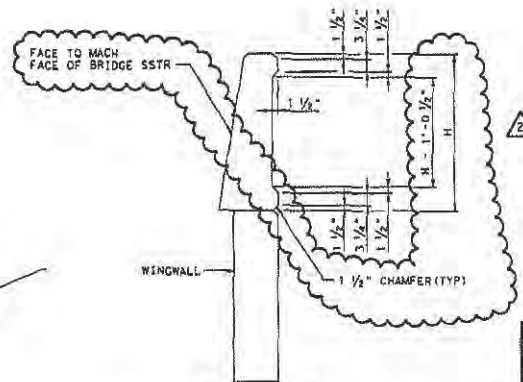
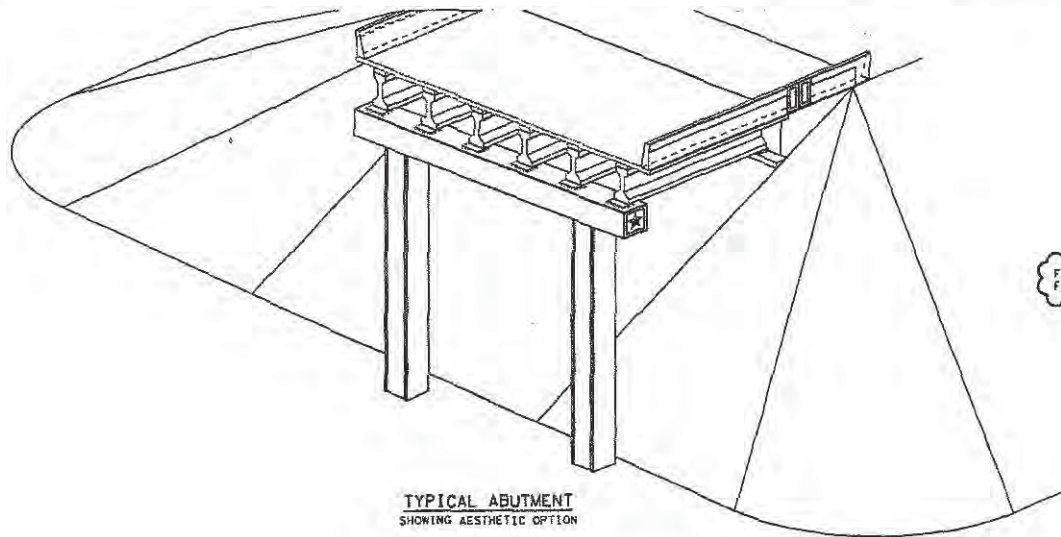

RELEASED FOR CONSTRUCTION
MAY 16 2005
Lone Star Infrastructure



B. Doosch
5/3/05



TEXAS DEPARTMENT OF TRANSPORTATION
AESTHETIC DETAILS
ABUT/SSTR AESTHETIC DETAILS
AESTB (SPL)

SHEET 1 OF 1

DESIGNED BY: MD	CHECKED BY: KJK	DATE: 08-21-04
DRAWN BY: JLS	SCALE: 1/8" = 1'-0"	DATE: 05-21-04
APPROVED BY: MD	DATE: 05-21-04	PROJECT NO:
FED. FEE: A10 PROJECT NO: 1 SHEET NAME: 1 DISC NO:		
6 86-2XX0001 BRS-111		
STATE: TX	DISTRICT: AUE	COUNTY:
CONTRACT:	SECTION:	JOB:
		HIGHWAY NO: 51130

Terracotta-Federal Standard I.D. No. 30252 shall be replaced with HC117 Silk Chocolate.
Buff-Federal Standard I.D. No. 33711 shall be replaced with HC136 Aztec Sand.

REV	DATE	BY	DESCRIPTION
0	05/23/04	HW	APPROVED FOR CONST
1	03/28/05	HW	378 AFC

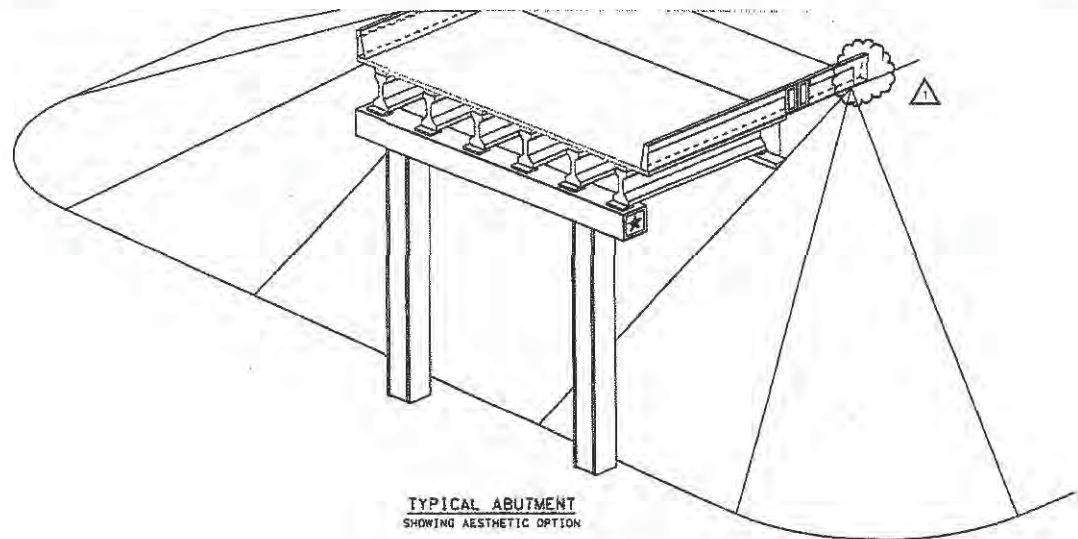

TYPICAL ABUTMENT
SHOWING AESTHETIC OPTION

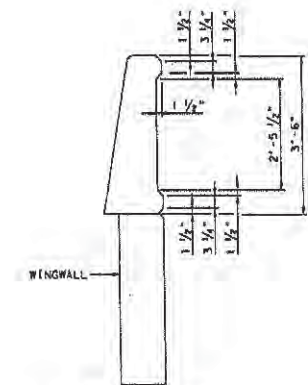

SECTION A-A
42" SSTR SHOWN (36" SSTR SIMILAR)

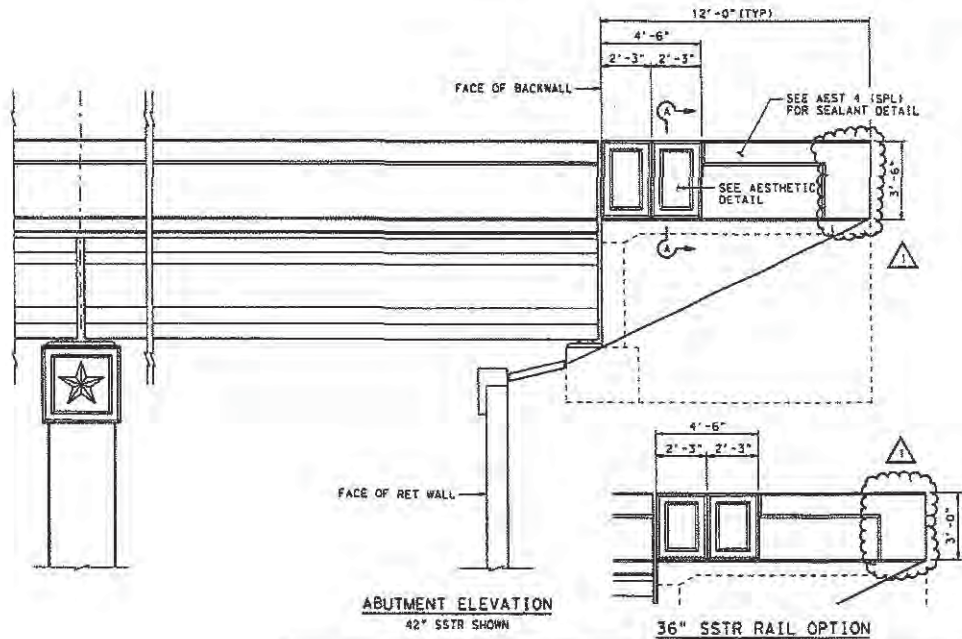

ABUTMENT ELEVATION
42" SSTR SHOWN

36" SSTR RAIL OPTION

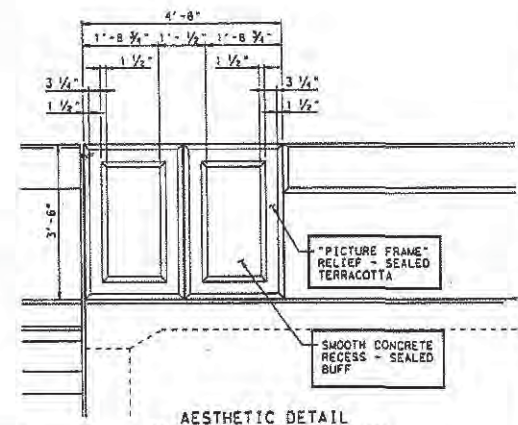

AESTHETIC DETAIL
42" SSTR SHOWN (36" SSTR SIMILAR)

RELEASED FOR
CONSTRUCTION
APR 12 2005
Lone Star Infrastructure



Bradley 3/24/05



TEXAS DEPARTMENT OF TRANSPORTATION
AESTHETIC DETAILS
ABUT/SSTR AESTHETIC DETAILS
AESTB(SPL)

SHEET 1 OF 1

DESIGNED BY	AD	CHECKED BY	ALM	DATE	08-21-04
DRAWN BY	TLW	CHECKED BY	HW	DATE	04-21-04
PROJECT NO.	86-2XKDB001	SHEET NAME	BR5-111	DWG NO.	
STATE	DISTRICT	COUNTY			
TX	ALIS				
COUNT	SHEET	JOB	HIGHWAY NO.		
			541 171		

Terracotta-Federal Standard I.D. No. 30252 shall be replaced with HC117 Silk Chocolate.
Buff-Federal Standard I.D. No. 33711 shall be replaced with HC136 Aztec Sand.

REV.	DATE	BY	DESCRIPTION

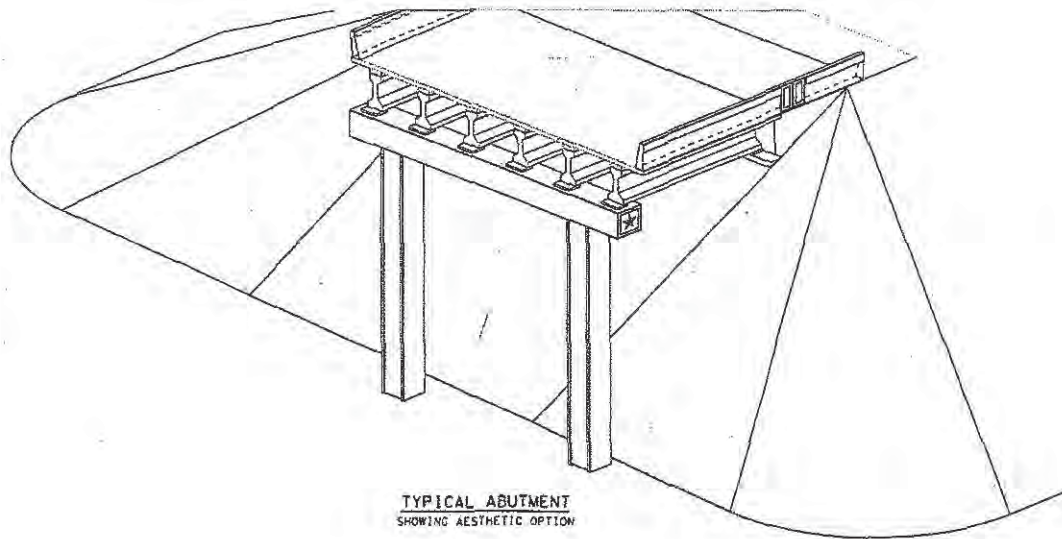

TYPICAL ABUTMENT
SHOWING AESTHETIC OPTION

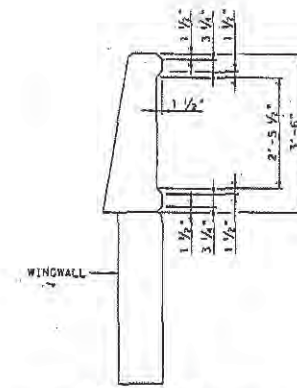

SECTION A-A
42" SSTR SHOWN (36" SSTR SIMILAR)

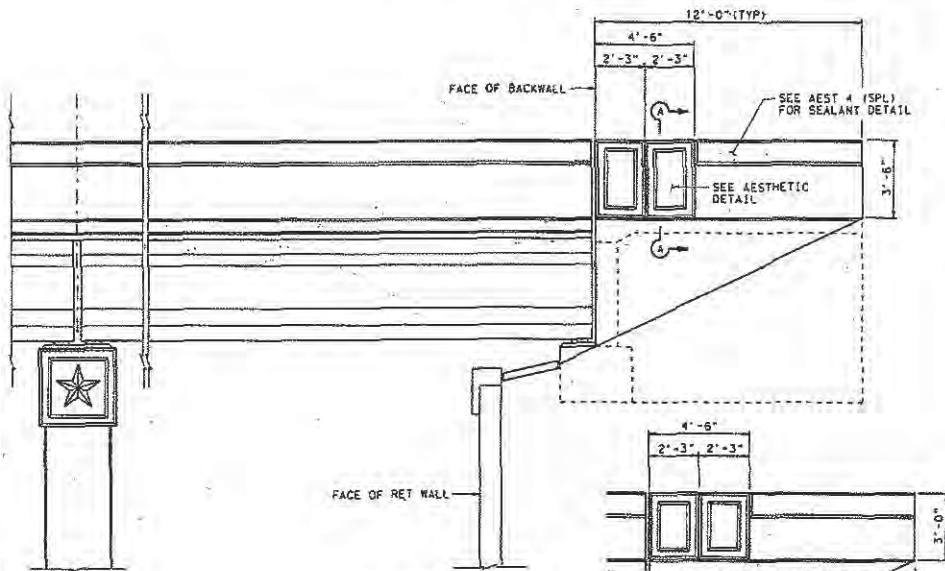

ABUTMENT ELEVATION
42" SSTR SHOWN

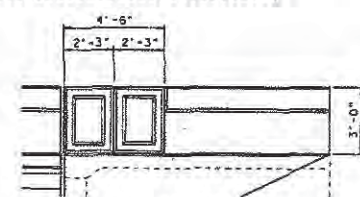

36" SSTR RAIL OPTION

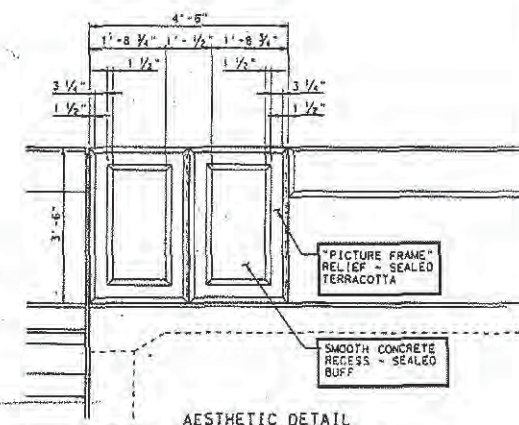

AESTHETIC DETAIL

BRIDGEPARMERS
ASSOCIATES, INC.
 CONSULTING ENGINEERS
 Approved
 The above design has been submitted through the Design QTRA process and meets the US approved Design QTR/2008
 Approved except as noted: See Design Exception Letter No. *1000000000*
Mansoor Alsharrah
 Design Quality Assurance Manager
 Mansoor Alsharrah, P.E.



Brian W. Dodson



TEXAS DEPARTMENT OF TRANSPORTATION

AESTHETIC DETAILS
 ABUT/SSTR AESTHETIC DETAILS
 AESTRISPL1

SHEET 1 OF 1

DESIGNED BY: BR	CHECKED BY: JLM	DRAWN BY: JLM	DATE: 03-31-04
CALCULATED BY: JLM	DESIGNED BY: BR	DRAWN BY: JLM	DATE: 03-31-04
APPROVED BY: JLM	DATE: 03-31-04	PROJECT NO:	
FILED: 03-31-04	PROJECT NO:	SHEET NAME:	DWG. NO.
S. 05-2X08001	BR5-111		
STATE:	DISTRICT:	COUNTY:	
TX	AUS		
CONE:	SECT:	JOB:	INVENTORY NO:

Terracotta-Federal Standard I.D. No. 30252 shall be replaced with HC117 Silk Chocolate.
 Buff-Federal Standard I.D. No. 33711 shall be replaced with HC136 Aztec Sand.